



SKYBLADE® FAN CO.
Where Form Follows Function

TURBOPROP SERIES

Patent pending

6'-16'



INSTALLATION MANUAL

Custom Designed

Reduced Maintenance

STOL Technology



IMPORTANT

READ AND SAVE THESE INSTRUCTIONS.

A printable, electronic version is available online at skybladefans.com.

⚠ WARNING/AVERTISSEMENT



Improper installation, adjustment, alteration, service or maintenance can cause property damage, injury or death. Read and understand the installation, operating and maintenance instructions thoroughly before installing or servicing this equipment.

Une installation, un réglage, une modification, un service ou d'entretien peuvent causer des dommages matériels, des blessures ou la mort. Lire et comprendre les instructions d'installation, d'exploitation et d'entretien avant d'installer ou de réparer ce matériel.

To Reduce the Risk of Fire, Electric Shock, or Injury to Persons, Observe the Following:



Installation work and electrical wiring must be done by qualified person(s) in accordance with all applicable codes and standards, including fire-rated construction. Failure to comply could result in personal injury, electric shock, death, fire and/or property damage.

Before attempting installation, servicing or cleaning unit, switch power off at the service panel and lock the service disconnecting means to prevent power from being switched on accidentally.

Pour réduire le risque d'incendie, de choc électrique ou de blessures, observer les points suivants:

Les travaux d'installation et le câblage électrique doivent être effectués par une personne qualifiée (s) en conformité avec tous les codes et normes applicables, y compris la construction coupe-feu. Le non-respect peut entraîner des blessures corporelles, de choc électrique, la mort, un incendie et / ou des dommages matériels.

Avant d'entreprendre l'installation, l'entretien ou un nettoyage, coupez l'alimentation électrique au panneau de service et bloquez les dispositifs de sectionnement pour éviter une mise en marche accidentelle.

ATTENTION:

SENSITIVE ELECTRONIC EQUIPMENT

- Ensure appliance input voltage does NOT exceed 460V on 3 phase models.
- Completely de-energize input power prior to wiring (do not "live wire").
- Damage to electronics due to improper electrical installation or inaccurate electrical supply is non-warrantable.
- Review IOM for specific electrical requirements.

- Single phase (115V or 230V) Prop Fans are shipped with a 115V plug. For 230V/1P, scan QR code for wiring instructions.





IMPORTANT

CAUTION/ATTENTION

The installation must be in accordance with the requirements specified in this installation manual and with any additional requirements set forth by the national electric code (NEC), ANSI/NFPA 70-1999, and all local codes. Failure to comply with these codes could result in personal injury or property damage.

L'installation doit être en conformité avec les exigences spécifiées dans le présent manuel d'installation et avec des exigences supplémentaires prévues par le code électrique national (NEC), ANSI / NFPA 70-1999, et tous les codes locaux. Le non respect de ces codes peut entraîner des blessures ou des dommages matériels.

The installation of this fan requires the use of power tools. Follow the safety procedures found in the owner's manual of these tools and do not use them for purposes other than those intended by the manufacturer.

L'installation de ce ventilateur nécessite l'utilisation d'outils électriques. Suivez les consignes de sécurité figurant dans le manuel du propriétaire de ces outils et ne pas les utiliser à des fins autres que celles prévues par le fabricant.

This unit has an unguarded impeller. Do not use in locations readily accessible to people or animals.

Cet appareil possède une roue sans surveillance. Ne pas utiliser dans des endroits facilement accessibles pour les personnes ou les animaux.

Use this unit only in the manner intended by the manufacturer. If you have questions, contact the manufacturer. The limited warranty does not cover equipment damage or failure that is caused by improper installation.

Utiliser cet appareil uniquement de la manière prévue par le fabricant. Si vous avez des questions, contactez le fabricant. La garantie limitée ne couvre pas les dommages à l'équipement ou de l'échec qui est causé par une mauvaise installation.

This appliance can be used by children aged from 8 years and above and persons with reduced physical, sensory or mental capabilities or lack of experience and knowledge if they have been given supervision or instruction concerning use of the appliance in a safe way and understand the hazards involved. Children shall not play with the appliance. Cleaning and user maintenance shall not be made by children without supervision.



CONTENTS

1	Fan Diagram	6
2	Important Information	7
3	Mounting Considerations	8
4	Preparing the Work Site	9
5	Mounting Method 1: Unistrut	10
	Mounting Method 2: Angle Iron	12-16
	Mounting Method 3: I-Beam	17
	Mounting Method 4: Purlins	18-19
6	Hanging the Fan	20-21
7	Installing Guy Wires	22-23
8	Installing Blades	24-27
9	Electrical	28-32
10	Troubleshooting	33-35
11	Parts	36
12	User Servicing Instructions	37-38

TurboProp Control and Power Assembly (patent pending)

MODEL	DESCRIPTION	LENGTH	WIDTH	HEIGHT	SHIPPING WEIGHT
TurboProp	Control & Power Assembly	30.5" (775mm)	33.0" (838mm)	30.5" (775mm)	140 lbs (64kg)

Mini-Eppler Blades (patent pending)

MODEL	DESCRIPTION	WIDTH (X)	LENGTH (Y)	HEIGHT (Z)	SHIPPING WEIGHT
0618-8	6' / 1.8M Fan	8" (203 mm)	36" (914 mm)	9" (229 mm)	22 lbs. (10 kg)
0824-8	8' / 2.4M Fan	8" (203 mm)	48" (1219 mm)	9" (229 mm)	27 lbs. (12 kg)
1030-8	10' / 3.0M Fan	8" (203 mm)	60" (1524 mm)	9" (229 mm)	33 lbs. (15 kg)
1236-8	12' / 3.6M Fan	8" (203 mm)	72" (1829 mm)	9" (229 mm)	38 lbs (17 kg)
1443-8	14' / 4.3M Fan	8" (203 mm)	84" (2134 mm)	9" (229 mm)	43 lbs. (20 kg)
1649-8	16' / 4.9M Fan	8" (203 mm)	96" (2438 mm)	9" (229 mm)	48 lbs (22 kg)



WHAT'S IN THE BOX

Prior to installation, verify that you have received all fan contents included with your system by checking them against the packing list. Materials not included in the fan contents (e.g., Grade 5 hardware, etc.) are the responsibility of the installer. Notify your product representative or Skyblade Fan Company of any discrepancy or missing kit contents prior to installing unit.

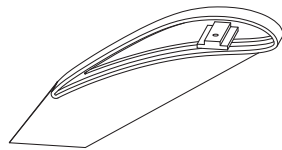

Wingtip (x8)

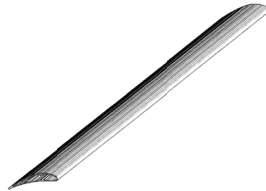

Blade (x8)

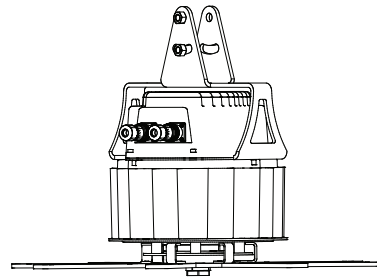

Motor & Chassis (x1)

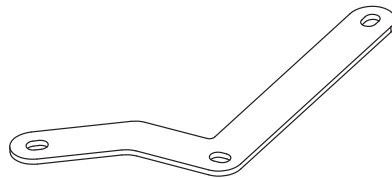

Blade Boomerang Bracket (x8)

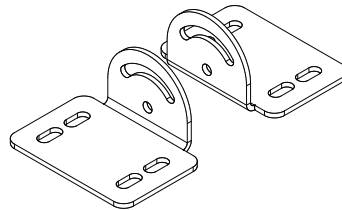

Upper Yoke (x2)

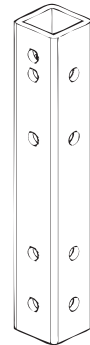

Extension Tube (x1)

Gripple Packet

5	Gripple Fasteners
4	15' Guy Wires
1	5' Safety Cable

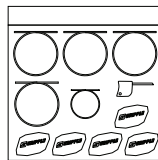

Hardware Packet 2 (Blade Assembly)

8	Soc Cap 5/16-18 x 5/8
8	Soc Cap 5/16-18 x 3/4
16	Zinc Split Lock Washer 5/16
8	BTN Cap Screw 10-32 X 3/8

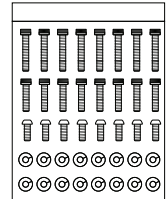

Hardware Packet 1 (Mounting Assembly)

4	Bolt - GR5 1/2" -13x 2 1/2"
4	Bolt - GR5 1/2-13x3-1/2"
16	Zinc Flat washer 1/2"
8	Nylock Nut - GRC 1/2-13"

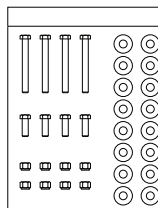

Hardware Packet 3 (Extra Hardware)

1	Bolt - GR5 1/2"-13x3-1/2"
1	Bolt - GR5 1/2" - 13 x 2 1/2"
3	Zinc Flat Washer 1/2"
3	Nylock Nut - GRC 1/2"-13
2	Soc Cap 5/16"-18 x 3/4
2	Soc Cap 5/16"- 18 x 5/8
3	Zinc Split Lock Washer M8
1	BTN Cap Screw 10-32 X 3/8

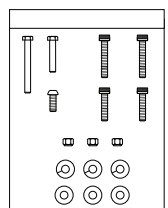

Reference Controller Brochure for additional hardware.

1 FAN DIAGRAM

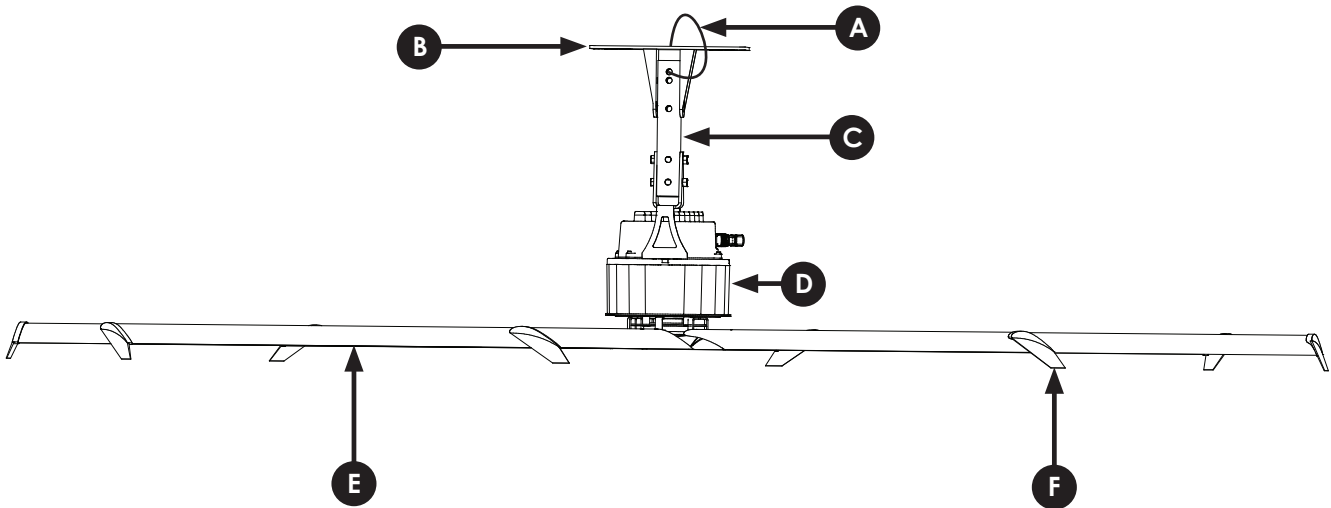

- A. **Safety Cable:** Used as a redundant safety feature that secures the fan to the mounting structure.
- B. **Upper Yoke:** Secures the fan to the structure and allows the fan to hang in a vertical direction.
- C. **Extension Bar:** Extends the fan from the ceiling to reach optimum operating height.
- D. **Chassis:** Housing for the motor and gear reducer
- E. **Blade:** Provides air movement.
- F. **Wingtip Fence:** Improves air movement efficiency by reducing drag.

SERIES	TBP	TBP	TBP	TBP	TBP	TBP
DIAMETER	6' / 1.8M	8' / 2.4M	10' / 3.0M	12' / 3.6M	14' / 4.3M	16' / 4.9M
BLADES	8	8	8	8	8	8
VOLTAGE INPUT	120/1 230/1 230/3 460/3	120/1 230/1 230/3 460/3	120/1 230/1 230/3 460/3	120/1 230/1 230/3 460/3	120/1 230/1 230/3 460/3	120/1 230/1 230/3 460/3

Model Number Ordering Format: SERIES-DIAMETER-BLADES-INPUT VOLTAGE-PHASE

Sample Model Number: TBP-1443-823-3

NOTE: 277V power source is not accepted.

2

IMPORTANT INFORMATION

2.1 Skyblade Safety Components

Skyblade fans are designed with redundant safety features to provide protection in the unlikely event of a catastrophic failure. Follow installation instructions carefully when installing fans.

2.2 Fan Spacing's and Placement

A standard ceiling fan should be mounted so that the bottom of the fan's hub is 33 inches below the ceiling which it is mounted. Fan blades should be mounted between 10' and 50' above the floor with optimum height between 20'-30'. If desired, extension bars are available to lower the fan if needed. Avoid mounting fans directly below lights or skylights to avoid a strobe effect caused by the moving blades.

When mounting a fan in an area where objects may be lifted or moved into the path of the fan, Skyblade Fans recommends marking or painting hash lines on the floor to alert personnel of the above movement of the fan.

The area within 15% of the diameter when the fan is at rest is considered "close clearance". It is extremely dangerous to mount the fans within "close clearance" of any object or path of object. We strongly recommend not mounting the fan closer than 15% of its diameter to any object or its path. If this is an issue, mounting extension bars and smaller fans are available from Skyblade Fans.

2.3 Fire Suppression Systems and Fan Placement

If installing Fans in a location where fire sprinklers are in place, do not interfere with their correct operation. Fans should be located in the center of each sprinkler quadrant and no less than 3 feet below the sprinkler. Review all codes applicable to sprinkler systems prior to installation; it is the customer's responsibility to see that the installation is completed to code and that it is correct.

2.4 Shielded Motor Cable

To minimize electromagnetic interference and stray voltage, SkyBlade Fan Company recommends the use of shielded input voltage cable. This shielded system reduces the likelihood of broadcasting and receiving electronic noise which can interfere with radio and other sensitive equipment. This shielded motor cable and the controller cable must be run in separate conduit at least 6 inches apart. Electrical interference and stray voltages are the liability of the installer and are not covered by SkyBlade under warranty.

2.5 Check Compliance with Federal, State, and Local Codes

Check all relevant codes to make sure product certifications, product listings, and building regulations are met. Code compliance is the responsibility of the installer.

3.1 General Mounting

Each type of mounting system requires a specific mounting bracket. Most are available from Skyblade Fans. Check with the contractor, building owner, or architect to ensure the structure is sound and will support the weight of the fan before beginning installation. Skyblade Fans provides guidelines for mounting fans; however, it is the sole responsibility of the building owner and installer to ensure the safety of the mounting system, that the building structure is sound, and the installation complies with all federal, state, and local codes.

⚠ CAUTION/ATTENTION

When cutting or drilling into a wall or ceiling, take care not to damage electrical wiring or other utilities.

Lorsque vous coupez ou percez un mur ou un plafond, prenez garde à ne pas endommager les fils électriques ou d'autres services publics.

Select a location that is free from obstructions that may interfere with the fan's operation.

Choisissez un emplacement qui est libre de tout obstacle pouvant interférer avec le fonctionnement du ventilateur.

3.2 Weight

A Standard 1.35-horsepower, TurboProp Series 16 foot 8-blade fan and mounting assembly weighs about 140 pounds. In inverted-blade applications designed to blow air upward, there is an additional downward force of about 80 pounds due to fan thrust. We recommend applying a safety factor of 2 times the stated hanging weight of the fan when determining the capabilities of the building structure.

3.3 Safety Cable

A Skyblade fan should never be run without proper installation of Safety Cables. These are supplied with every fan. You must install safety cable for warranty to be in effect.

3.4 Guy Wires

While in operation a fan can sway due to minor imbalance or because of wind. Since the mounting system is capable of swiveling, it will not stop fan movement, so it is important that the guy wires be installed properly. Proper installation includes the angle and tension of the guy wires. See page 22-23 for more information.

3.5 Universal Mounting Hardware

We recommend mounting the fan to a horizontal structural beam, however, this is not always possible in buildings with pitched roof construction. For this reason, our universal mounting system is designed to allow the fan to hang in a level position perpendicular to the ground by rotating the upper yoke 90 degrees.

4

PREPARING THE WORK SITE

4.1 Mechanical Installation

A 16' (4.9m) TurboProp fan (our largest model) weighs, at maximum, 140 lbs (64kg). A scissor lift, or other suitable means for lifting and a minimum of two installation personnel, will be required.

Skyblade Fans can be hung from a unistrut, angle irons, or an I-beam. See installation instructions on the following page. Do not mount the fan to single purlins, trusses, or bar joists. Consult a structural engineer for installation methods not covered in the manual.

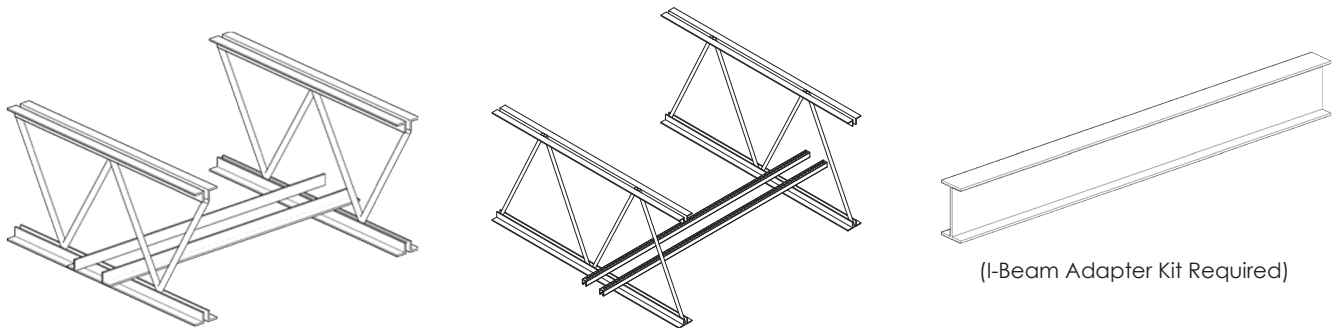

⚠ CAUTION/ATTENTION

To reduce the risk of injury to persons, install the fan so that the blade(s) is at least 10 feet (3.05 meters) above the floor.

Pour réduire le risque de blessures, installez le ventilateur de sorte que la lame (s) est d'au moins 10 pieds (3,05 mètres) au-dessus du sol.

The fan installation area and path must be free of obstructions such as lights, cables, sprinklers, or other building structure. We strongly recommend not mounting the fan closer than 15% of its diameter to any object or its path.

Do not install the fan where it will be continuously subjected to high winds (ex. Under a high velocity HVAC system). Allow a required 2x the fans diameter between the fan and the HVAC (or other air-moving) equipment when measured from the center of the fan to the equipment.

The spacing between multiple fans should be no less than 2.5x the fans diameter when measured from the center of the fans.

The mounting structure must be able to withstand the torque which is generated by the fan. A 20' diameter fan generates a maximum of nearly 300 ft-lb (406.7 N-m) of torque during operation.

4.2 Electrical Installation

To reduce the risk of electrical shock, wiring should be performed by a qualified electrician. Incorrect assembly can cause electric shock or damage the motor and controller.

The installation of a Skyblade Fan must comply with the National Electrical Code, ANSI/NFPA 70-1999, and all local codes.

All unused conductors that share conduit with the AC supply feeds must be grounded on both ends.

If required, a local disconnect should be installed per NEC and all local codes.

Refer to specifications on page 31 for appropriate circuit requirements.

Each fan requires dedicated branch circuit protection.

5 MOUNTING METHOD 1: UNI-STRUT

⚠ WARNING/ AVERTISSEMENT



Support Directly From Building Structure.

All mounting instructions assume that the building structure from which the fan will be hung is of sound construction, undamaged, and capable of supporting loads of up to 650 lbs (295 kg). It is the sole responsibility of the customer to verify that the building's structure is adequate for fan installation. Skyblade Fans recommends consulting with a structural engineer prior to fan installation.

Aider directement à la structure du bâtiment.

Toutes les instructions de montage supposent que la structure du bâtiment à partir de laquelle le ventilateur sera pendu est de construction solide, en bon état, et capable de supporter des charges de jusqu'à 650 lb (295 kg). Il est de la seule responsabilité du client de vérifier que la structure du bâtiment est suffisante pour l'installation du ventilateur. Skyblade fans recommande de consulter un ingénieur en structure avant d'attiser installation.

5.1 Select Proper Unistrut:

NOTE: Unistrut and Unistrut hardware is not included with the fan. This equipment must be field supplied.

(2) 1-5/8" Unistrut Channels (not provided).

If the spanning distance is greater than 8 feet, please consult a structural engineer.

Span two (2) pieces of 1-5/8" Unistrut open side facing down and space apart so there is 12-7/8" from outside edge to outside edge.

Once the Unistrut is in place, apply liquid thread lock to the recommended bolts and use the remaining recommended hardware to attach the mount to the Unistrut.

Follow the table below when selecting Unistrut for fan installation. PLEASE NOTE: These are recommendations. SkyBlade is not liable for accidents resulting from improperly sized mounting methods. Please consult a structural engineer.

Unistrut Span (between mounting point)	Minimum Unistrut Size (W x H x T)	Qty. of Unistrut Needed
< 8' (2.4m)	1-5/8"	2



5 MOUNTING METHOD 1: UNI-STRUT

5.2 Fasten Unistrut to Roof Structure Mounting Points:

Do not install the fan from a single purlin, truss, or bar joist.

Ne pas installer le ventilateur à partir d'une seule panne, botte, ou solives.

The unistrut must be fastened to the roof structure at each end.

L'Unistrut doit être fixé à la structure du toit à chaque extrémité.

Fasten the unistrut to the roof structure mounting points at each end with customer-supplied Grade 5 hardware as shown.

Fixez l'unistrut aux points de fixation de la structure du toit à chaque extrémité avec le matériel de qualité 5 fourni par le client, comme illustré.

ATTENTION: Do not tighten the hardware until the upper yoke has been mounted to the unistrut.

Grade 5 Hardware (customer supplied)

- a. (4) 1/2"-13 GR 5 Bolt
- b. (8) 1/2" Flat Washer
- c. (4) 1/2" Nylock Nut
- d. (4) 2-1/2" Square Washer

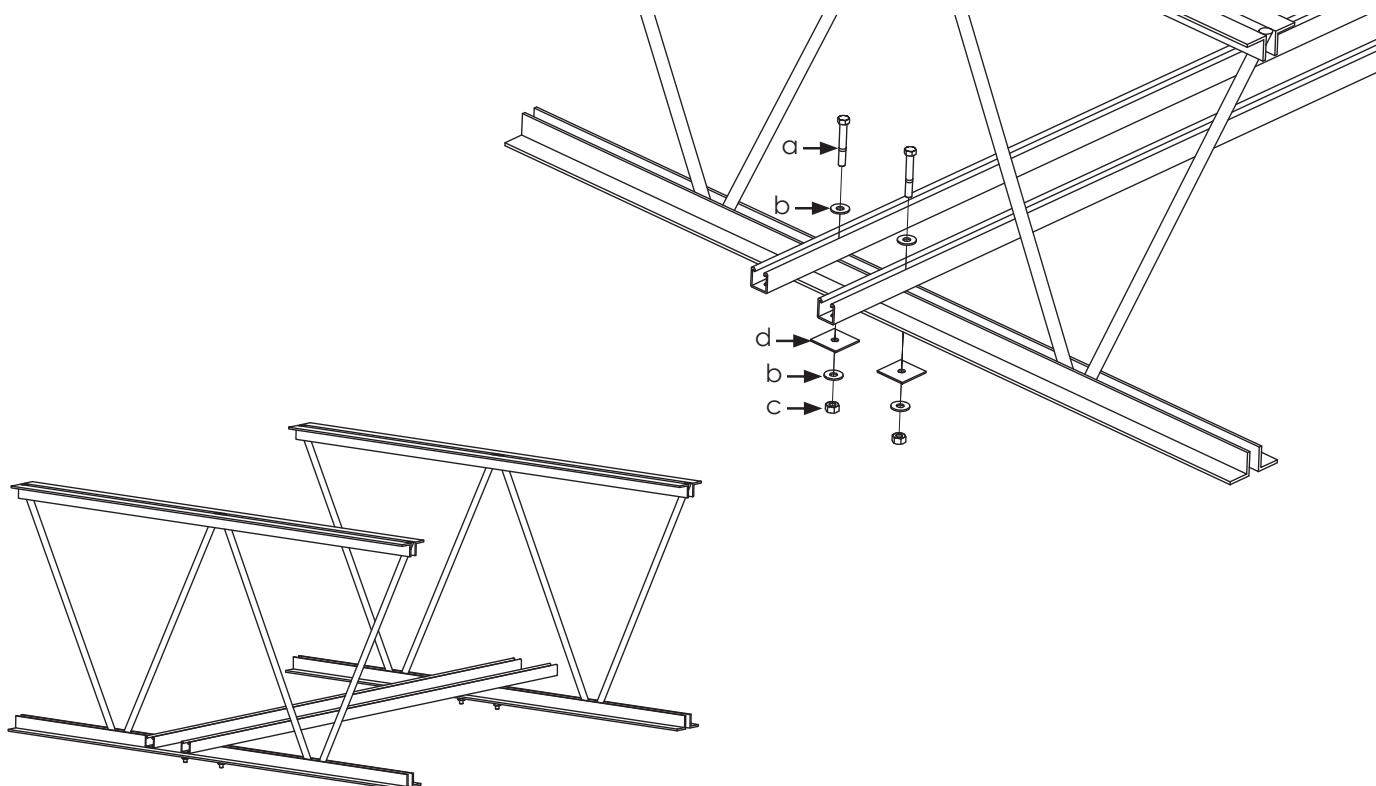

5 MOUNTING METHOD 2: ANGLE IRONS

⚠ WARNING/AVERTISSEMENT

Never use clamping plate or clamping shims when mounting the fan to angle irons!

Ne jamais utiliser la plaque de serrage ou des cales de serrage lors du montage du ventilateur à cornières!

Beam clamps are only intended for I-beam installations.

Serre-poutres sont uniquement destinées aux installations de faisceaux.

5.3 Select Proper Angle Irons:

NOTE: Angle Irons and angle iron hardware are not included with the fan.

⚠ CAUTION/ATTENTION

Do not install the fan from a single purlin, truss, or bar joist.

Ne pas installer le ventilateur à partir d'une seule panne, botte, ou solives.

Unsupported angle iron spans should not exceed 12' (3.7m).

Non pris en charge travées de fer d'angle ne doit pas dépasser 12 pi (3,7 m).

Do not install motor and hub assembly directly on angle iron.

Ne pas installer moteur et moyeu directement sur cornière.

Follow the table below when selecting angle irons for fan installation.

Angle Iron Span (between mounting point)	Minimum Angle Iron Dimensions (W x H x T)	Qty. of Angle Irons Needed
6' (1.8m) or less	2.5" (6.4cm) x 2.5" (6.4cm) x .25" (.6cm)	2
over 6' (1.8m) - 8' (2.4m)	3" (7.6cm) x 3" (7.6cm) x .25" (.6cm)	2
over 8' (2.4m) - 12' (3.7m)	3" (7.6cm) x 3" (7.6cm) x .25" (.6cm)	4*

*2 pairs of angle irons. Pairs should be placed back to back and fastened in center (see step 2).

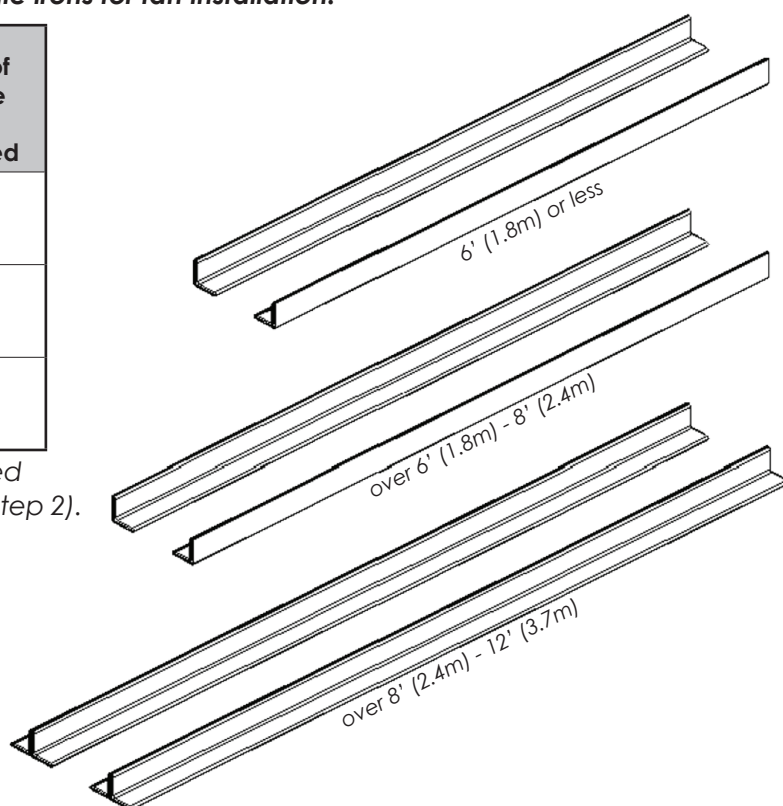
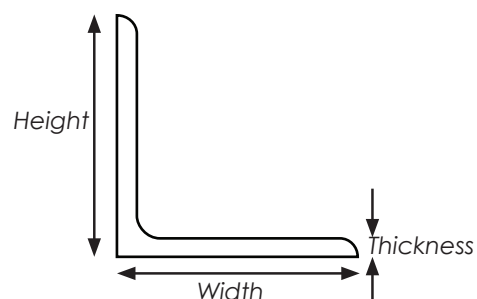

5

MOUNTING METHOD 2: ANGLE IRONS

5.4 Pre-Drill Angle Irons:

Drill two 9/16" (1.4cm) holes exactly 4" (10.16 cm) apart in the center of the two angle irons.

Measure the distance between the mounting points of the roof structure that the angle irons will span. Measure the same distance on the angle irons and drill 9/16" (1.4cm) diameter holes through each end of the angle irons. Drill holes in two angle irons if the span is 8' (2.4m) or less. Drill holes in 4 angle irons if span is greater than 8' (2.4m).

5.5. Fasten Angle Irons Together (if span is longer than 8')

If the angle iron span is 8' (2.4m) or less, proceed to step 5.6a on the following page.

If the angle iron span is longer than 8' (2.4m), it is necessary to use double angle irons.

Locate the center of the angle iron length. Drill 9/16" (1.4cm) diameter hole through the center of the vertical wall of the angle iron. Drilling through a total of four angle irons.

Place two drilled angle irons back to back. Fasten the angle irons together with customer supplied grade 5 hardware.

Align the angle irons to each other and tighten the bolts to 90 ft-lb (122 N-m) using a 3/4" socket with torque wrench.

Proceed to step 5.6b.

Grade 5 Hardware (customer supplied)

- a. (2) 1/2"-13 GR 5 Bolt
- b. (4) 1/2" Flat Washer
- c. (2) 1/2" Nylock Nut

5 MOUNTING METHOD 2: ANGLE IRONS

5.6a Fasten Single Angle Iron to Roof Structure Mounting Points:

If installation requires double angle irons (i.e., span is greater than 8' (2.4m)), proceed to step 5.6b.

ATTENTION: Do not tighten the hardware until the upper yoke has been mounted to the angle irons.

⚠ CAUTION/ATTENTION

Do not install the fan from a single purlin, truss, or bar joist.

Ne pas installer le ventilateur à partir d'une même purlin, botte, ou solives.

The angle irons must be fastened to the roof structure at each end.

Les cornières doivent être attachés à la structure de toit à chaque extrémité.

Fasten the angle irons to the roof structure mounting points at each end with customer-supplied Grade 5 hardware as shown.

Fixer les cornières aux points de fixation de la structure du toit à chaque extrémité fourni par le client 5 e année du matériel comme indiqué.

Proceed to step 5.7.

Grade 5 Hardware (customer supplied):

- a. (4) 1/2"-13 GR 5 Bolt
- b. (8) 1/2" Flat Washer
- c. (4) 2-1/2" Square Washer (see diagram)
- d. (4) 1/2" Nylock Nut

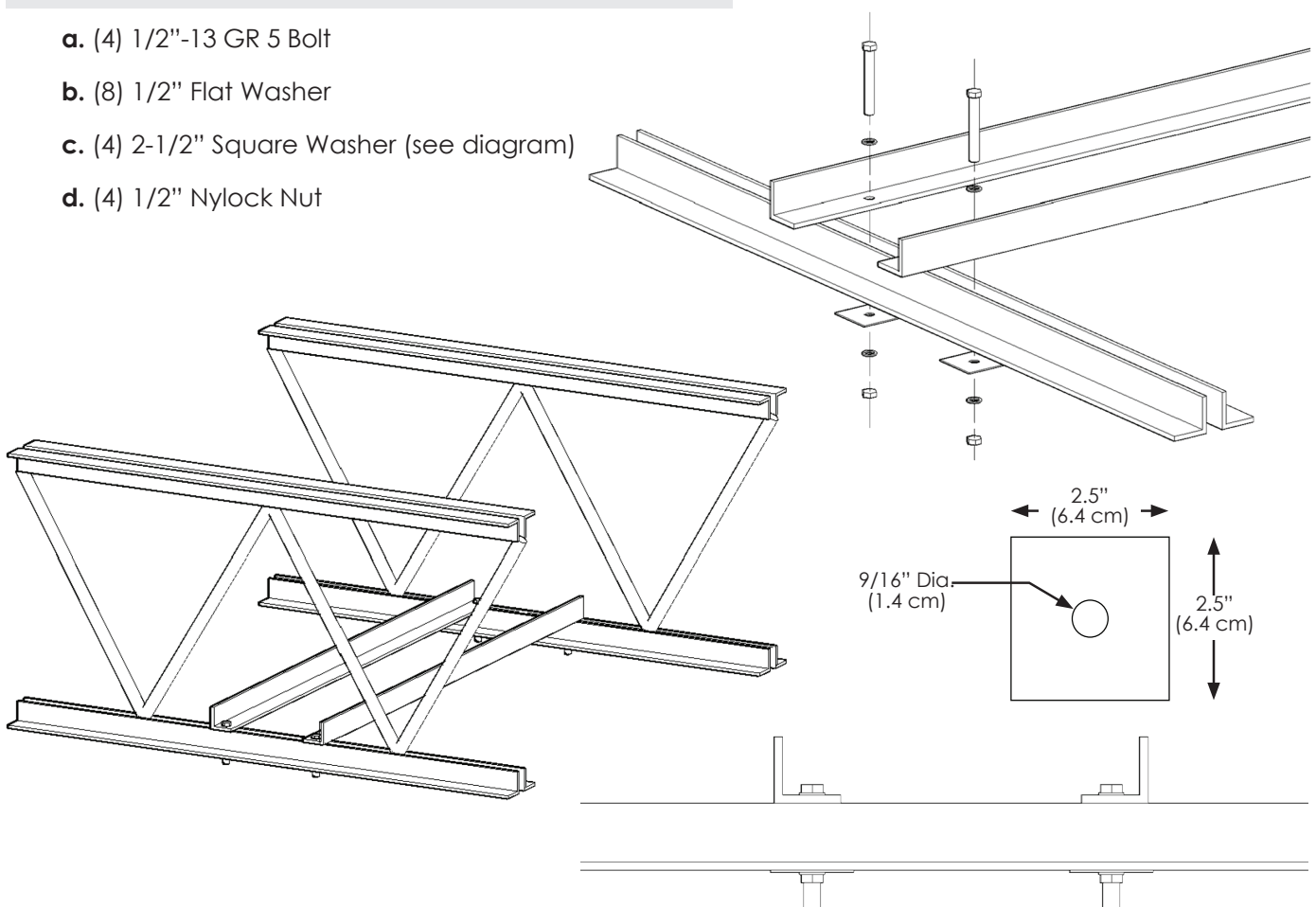

5 MOUNTING METHOD 2: ANGLE IRONS

5.6b Fasten Double Angle Irons to Roof Structure Mounting Points:

ATTENTION: Do not tighten the hardware until the upper yoke has been mounted to the angle irons.

⚠ CAUTION/ATTENTION

Do not install the fan from a single purlin, truss, or bar joist.

Ne pas installer le ventilateur à partir d'une même purlin, botte, ou solives.

The angle irons must be fastened to the roof structure at each end.

Les cornières doivent être attachés à la structure de toit à chaque extrémité.

Fasten the angle irons to the roof structure mounting points at each end with customer-supplied Grade 8 hardware as shown.

Fixer les cornières à la structure du toit de points de fixation à chaque extrémité fourni par le client matérielle la 8e année, comme illustré.

Proceed to step 5.7.

Grade 5 Hardware (customer supplied):

- a. (4) 1/2"-13 GR 5 Bolt
- b. (8) 1/2" Flat Washer
- c. (4) 2-1/2" Square Washer (see diagram)
- d. (4) 1/2" Nylock Nut

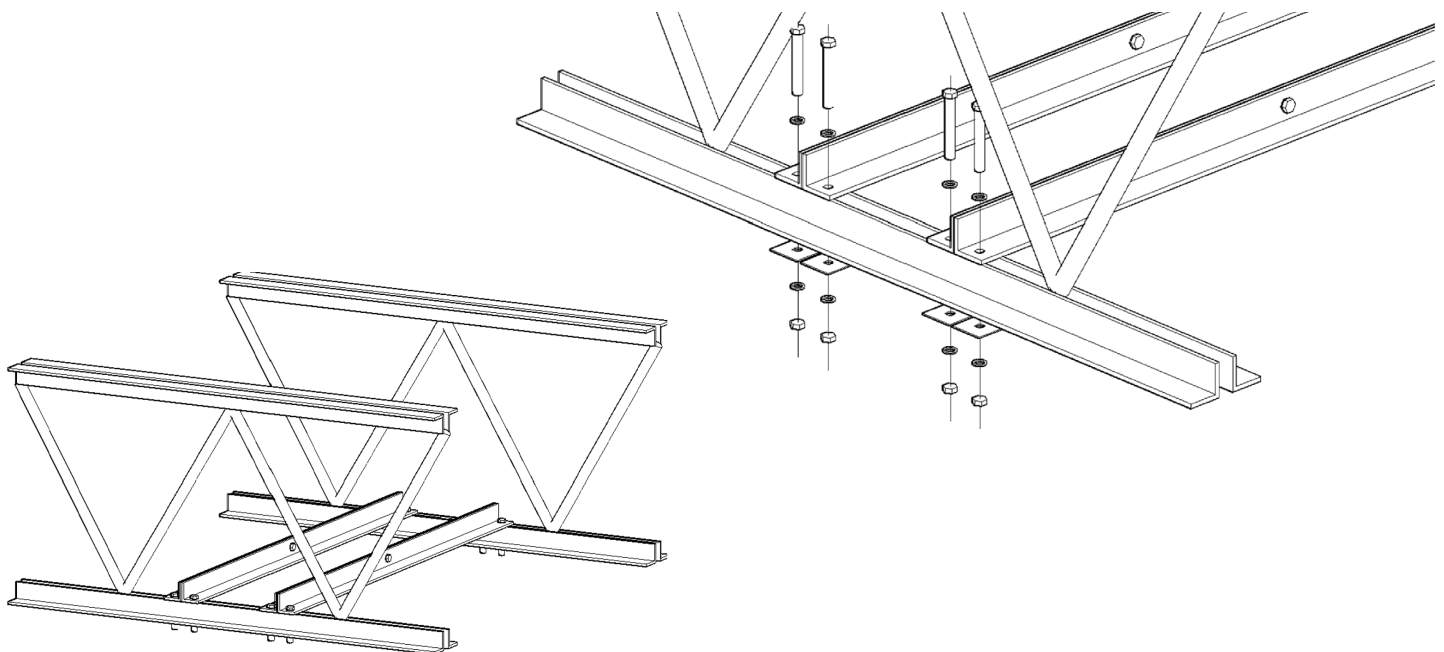
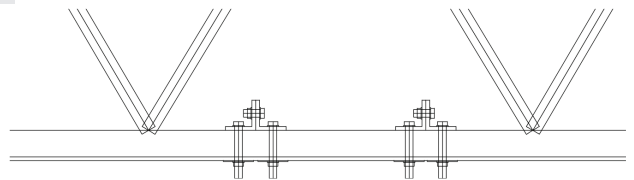

5 MOUNTING METHOD 2: ANGLE IRONS

5.7 Attach Upper Yoke (to Angle Iron):

Secure the upper yoke directly to the angle irons with the Beam Clamp hardware as depicted below. Consult the diagrams below for distances between the angle irons. Do not install the fan from a single purlin, truss, or bar joist.

Tighten bolts to 90 ft-lb (122 N-m) using a 3/4" socket and torque wrench.

⚠ CAUTION/ATTENTION

The angle irons should be aligned with the innermost holes of the upper yoke.

Les fers angulaires doivent être alignés avec les trous les plus à l'intérieur de la culasse supérieure.

After attaching upper yoke to the angle irons, tighten all the bolts securing the angle irons to the roof structure to 90 ft-lb (122 N-m) using a 3/4" socket with torque wrench.

Après l'avoir fixée culasse supérieure aux cornières, serrer tous les boulons de fixation des cornières à la structure du toit à 90 lb-pi (122 Nm) avec une "prise 3/4 avec une clé dynamométrique.

Upper Yoke Hardware (supplied):

- (4) 1/2"-13x2-1/2" GR 5 Bolt
- (8) 1/2" Flat Washer
- (4) 1/2"-13 Nylock Nut

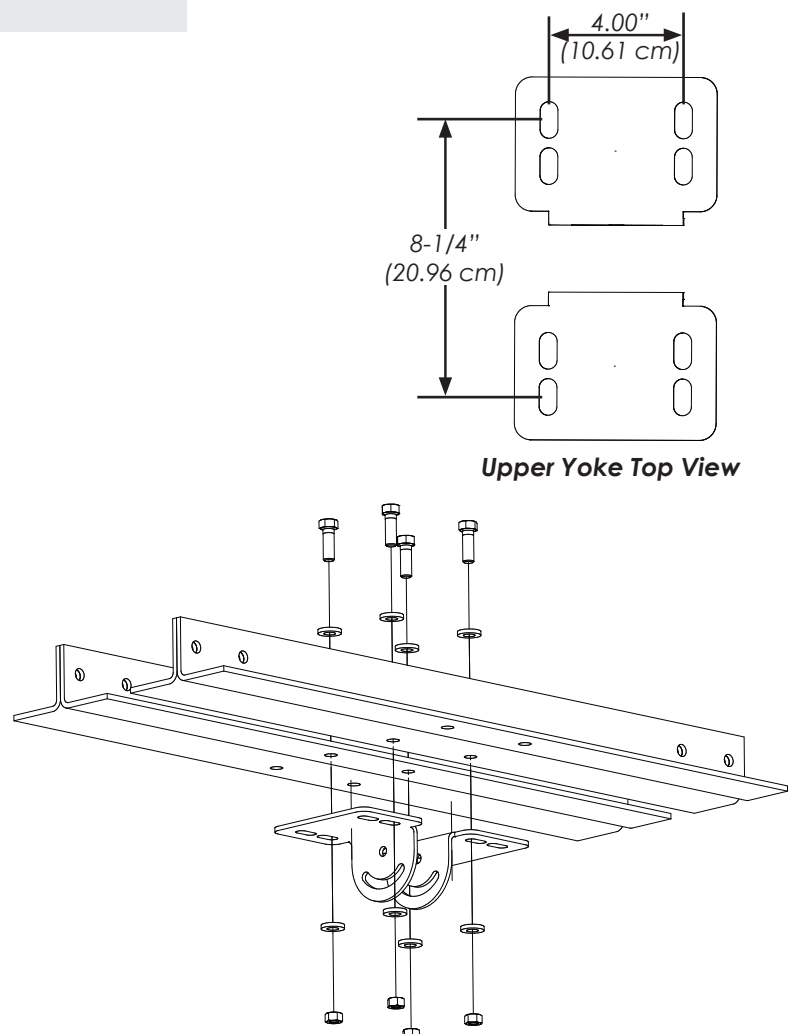
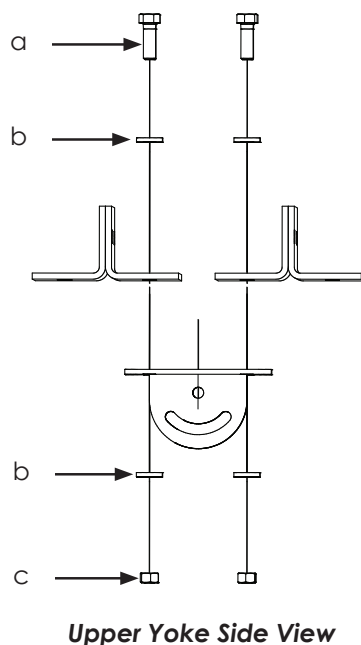

5 MOUNTING METHOD 3: I-BEAM

NOTE: Mounting to I-beams requires the purchase of the I-beam Adapter Kit in lieu of standard Upper Yoke from SkyBlade Fan Company.

⚠ CAUTION/ATTENTION

Install the "Clamping Shims" only if the thickness of the I-beam flange exceeds 3/8" (1cm). The mounting holes of the shim are closer to one side than the other. Make sure this side is facing the I-beam.

Installez les cales de serrage que si l'épaisseur de la semelle de la poutre supérieure à 3/8 "(1 cm). Les trous de fixation de la cale sont plus près d'un côté que de l'autre. Assurez-vous que ce côté est confronté à la poutre

5.8 Attach I-Beam Adapter (to I-Beam)

Measure the flange width of the I-beam you are wanting to hang the fan from. Compare the I-beam flange width to the diagram below to determine what mounting holes you will require.

Secure the upper yoke to the I-beam with the "Clamping Plate" hardware shown below. Tighten the bolts to 90 ft-lb, (122 N-m) using a 3/4" socket and torque wrench.

Proceed to "Hanging the Fan" on pg. 21.

Clamping Plate Hardware (purchased separately):

- a. (4) 1/2"-13x2 1/2" GR 5 Bolt
- b. (8) 1/2" Flat Washer
- c. (4) 1/2"-13 Nylock Nut
- d. (2) Clamping Plate

I-Beam Flange Width	Upper Yoke Mounting Holes
5" (12.7cm) 8-3/8" (21.2cm)	inner holes
>8-3/8" (21.2cm) 9" (22.8cm)	outer holes

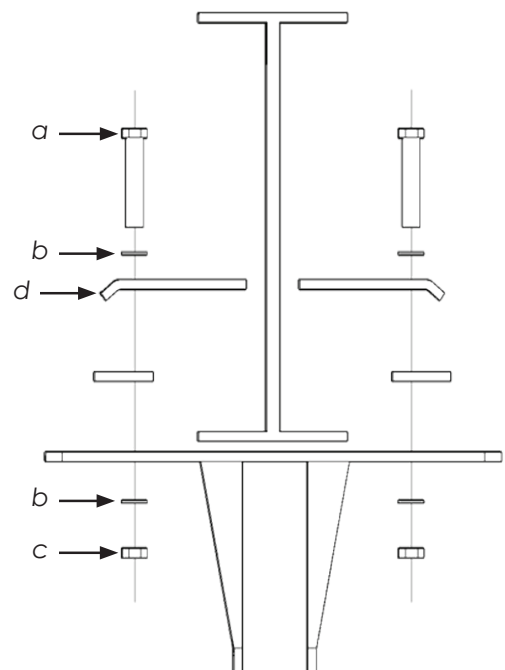
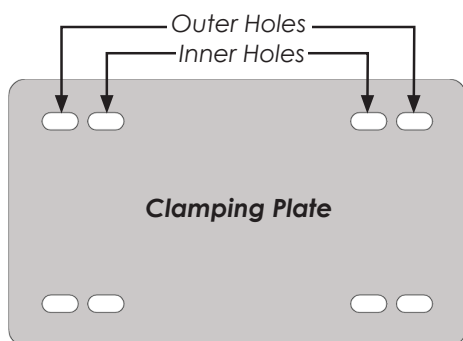

5 MOUNTING METHOD 4: PURLINS

NOTE: Purlin brackets and hardware are available from SkyBlade Fan Company upon request and not included standard.

5.9 Selecting Proper Angle Irons

Select the proper angle irons based on the requirements stated under section 5.3.

5.10 Pre-Drill Purlins

Drill four 9/16" (1.4 cm) diameter holes centered vertically along the purlin spaced apart 4.5" (11.4 cm) horizontally and 1.5" (3.8 cm) vertically. These holes should match up perfectly with those of the purlin bracket and back plate.

5.11 Attach Brackets and Backing Plates

Purlin mounting brackets and backing plates should be attached using the provided 1/2" grade 5 bolts, washers, and nylock nuts. A washer should be placed on both sides of the plate for each bolt.

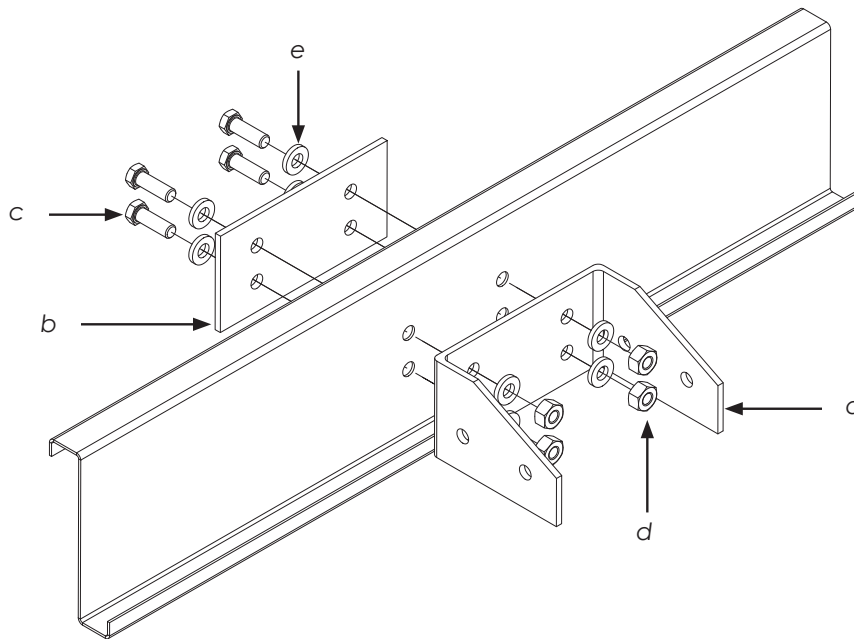

5.12 Pre-Drill Angle Iron Brackets Holes

Your angle iron should be cut to allow 1/2" (1.27 cm) clearance between the end of the angle iron and the purlin you are mounting to. Drill one 9/16" (1.4 cm) diameter hole centered vertically exactly 1" (2.54 cm) from the edge on both ends of the vertical wall of the angle iron. Drill a second hole exactly 3" (7.6 cm) inward from the first hole on both ends. Repeat for the second angle iron. These holes will be used to secure the angle iron to the purlin bracket with the provided hardware.

5.13 Pre-Drill Angle Iron Fan Mounting Holes

Measure the distance between the mounting points that each angle iron will span. Drill two 9/16" (1.4 cm) diameter holes centered on the bottom wall of each angle iron. The two holes should be spaced 5.5" (13.9 cm) apart to best match those of the upper yolk. These holes will attach the upper yolk to the angle iron.

5 MOUNTING METHOD 4: PURLINS

5.14 Mount Angle Iron

Attach the angle irons to the brackets using the provided 1/2" grade 5 bolts, washers, and nylock nuts. The angle irons must be facing outward secured to the outside faces of the purlin brackets.

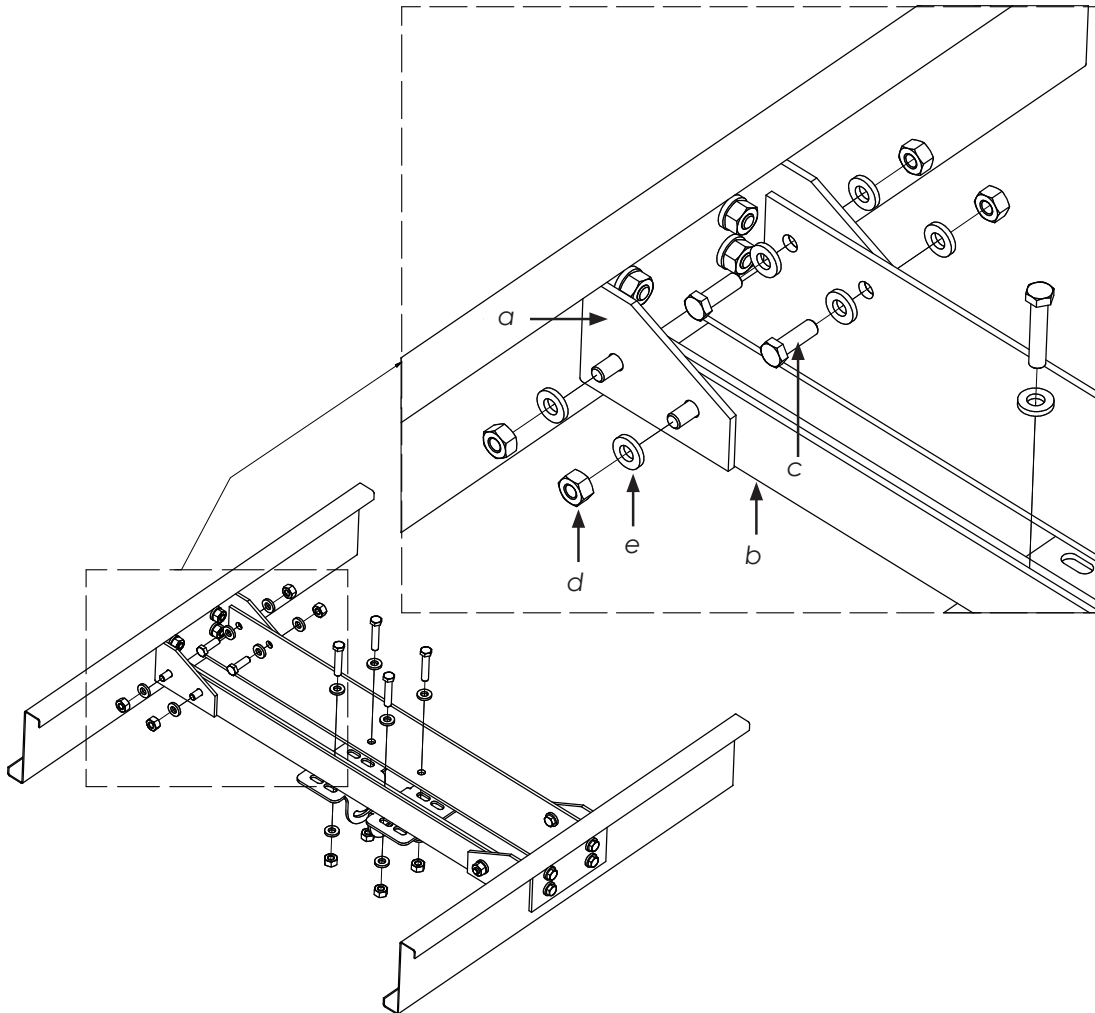

5.15 Attach Upper Yoke to Angle Iron

Attach the upper yoke to the angle irons using the provided 1/2" grade 5 bolts, washers, and nylock nuts. See section 5.7 "Attach Upper Yoke (to Angle Iron)" to continue installation.

Purlin Bracket Hardware (per set, supplied):

- a. (2) 1/4" Formed Steel Purlin Bracket
- b. (2) 1/4" Steel Purlin Backplate
- c. (16) 1/2"-13-1 3/4" GR 5 Bolt
- d. (16) 1/2" Nylock Nut
- e. (32) 1/2" Flat Washer

6 HANGING THE FAN

Before installation all set screws **must** be checked, and tightened where necessary, before installation.

6.1 Attach Extension Tube (to Upper Yoke):

Attach the extension tube to the upper yoke with the hardware shown.

Before tightening the bolts, allow the fan to hang freely from the structure to allow the fan to rest perpendicularly from the floor.

Tighten bolts to 90 ft-lb (122 N-m) using a 3/4" socket and torque wrench.

Single Pivot Hardware (supplied):

- a. (2) 1/2" - 13x 3 1/2" GR 5 Bolt
- b. (4) 1/2" Flat Washer
- c. (2) 1/2"-13 Nylock Nut

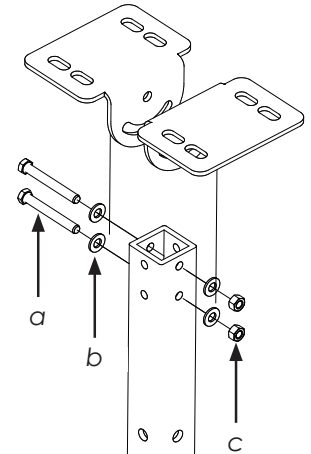

6.2 Secure Upper Safety Cable:

Secure the safety cable to the I-beam or angle iron by wrapping the safety cable around it, threading the cable through the 17/32" open hole on the top of the extension tube, and securing the ends with the gripple fastener as shown. The cable must have as little slack as possible. Securely tighten the gripple.

⚠ WARNING/ AVERTISSEMENT

The safety cable is a critical safety feature of the fan and must be installed correctly.

Le câble de sécurité est une caractéristique de sécurité essentielle de la soufflante qui doit être installé correctement.

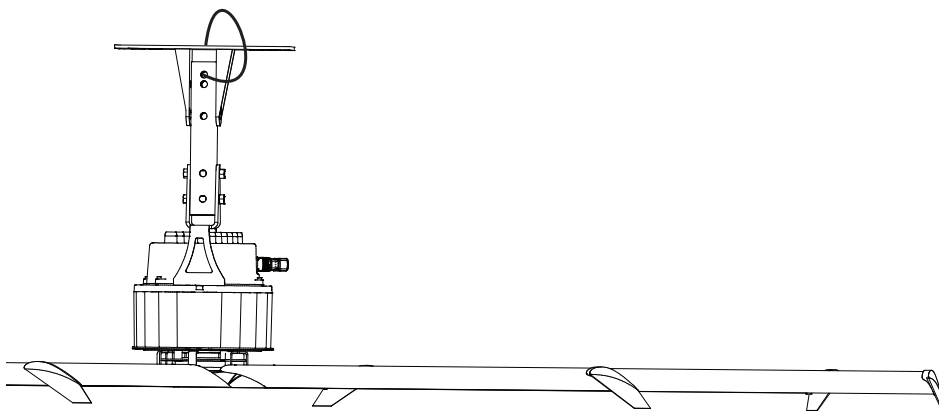

Cable End Detail

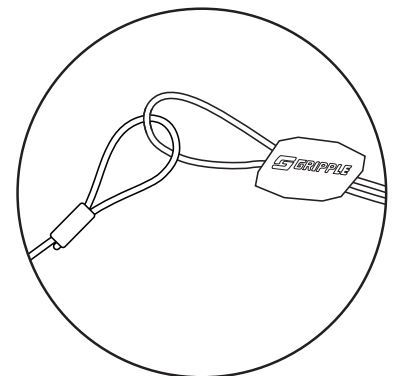

6 HANGING THE FAN

⚠ CAUTION/ATTENTION

The Motor Frame is heavy, use a minimum of two persons when raising it.

Châssis du moteur est lourd, utiliser un minimum de deux personnes lors de l'élevant.

⚠ WARNING/ AVERTISSEMENT

Failure to install fan **both horizontally and vertically level** will cause uneven wear in the motor and gearbox bearings which can lead to damage or a shortened lifespan. **Failure to install level will void manufacturer warranty.**

Le fait de ne pas installer le ventilateur **à la fois horizontalement et verticalement** entraînera une usure inégale du roulement du moteur et du roulement de la boîte de vitesses, ce qui peut entraîner des dommages ou une durée de vie raccourcie. **Ne pas installer le niveau annulera la garantie du fabricant.**

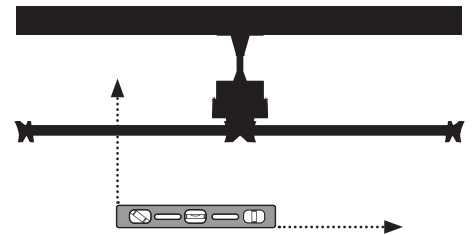

6.3 Attach the Motor (to extension tube):

Attach the lower yoke on the chassis to the bottom of the extension tube with the Lower Yoke Hardware as shown.

Tighten bolts to 90 ft. lbs. (122 N-m) using a 3/4" socket with torque wrench.

Lower Yoke Hardware (supplied):

- a. (2) 1/2"-13x3 1/2" GR 5 Bolt
- b. (4) 1/2" Flat Washer
- c. (2) 1/2"-13 Nylock Nut

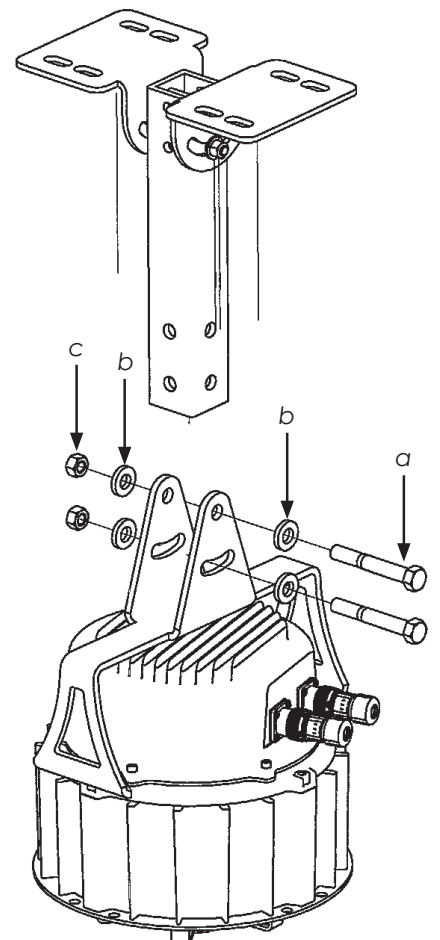

7.1 Installing the Guy Wires:

IMPORTANT! Disregarding this step will void the manufacturer's warranty.

The use of four guy wires, with one gripple per wire is required. The angle formed by the guy wire and the ceiling must be less than 45 degrees from horizontal. Eye bolts (not supplied) are recommended to attach guy wires to the ceiling or beam.

Gripping Hardware Kit (supplied):

- a. (4) 15' Wire Cables
- b. (1) 5' Wire Cable
- c. (5) Gripping Fasteners

It is recommended to use a level to confirm the fan is installed horizontal.

Use caution near sharp corners to avoid wear and/or fraying of the guy wires.

⚠ CAUTION/ATTENTION

Over-tightening the guy wires may cause the fan to become unbalanced.

Un serrage excessif des câbles de haubannage peut provoquer le ventilateur à devenir déséquilibré.

Guy wires should be spaced evenly around the fan and remain clear of the fan blade rotation path.

Les haubans espacer uniformément autour du ventilateur et restent dégagées de la voie de rotation de la pale de ventilateur.

Attach the guy wires to the ceiling or beam (reference Eye Hook illustration on page 23).

1. Slide the unlooped end of the guy wire through the eye hook.
2. Feed the wire through the loop on the other end of the wire.
3. Pull tight so the wire tightens on the eye hook.

Attach each guy wire to the loop on the mid-section of the motor.

1. Slide the gripping fastener (as supplied) over the opposite end of the wire.
2. Feed the end of the guy wire through the guy wire loop on the fan motor and then through the gripping, removing any slack from the cable.

7 INSTALLING GUY WIRES/GRIFFLE

When all of the guy wires are taut, trim the cables so no more than 3" extends from the gripple clamp.

⚠ WARNING/ AVERTISSEMENT

Make certain all electrical cords are not obstructed by guy wires.

Assurez-vous que tous les câbles électriques ne soient pas obstrués par des haubans.

Eye Hook (Ceiling)

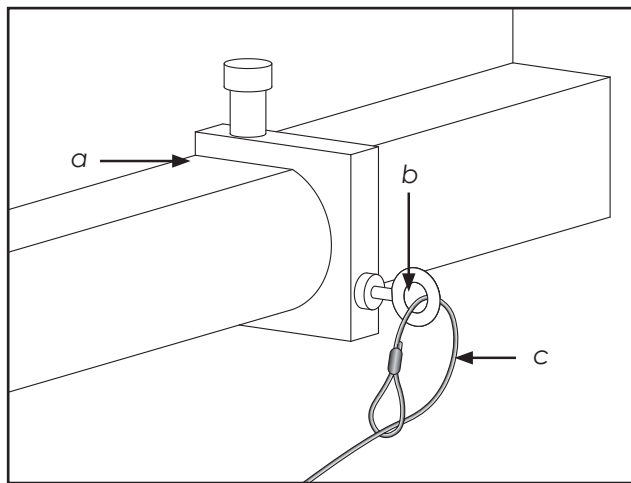

- a Beam Clamp
- b Eye Hook
- c Gripple Wire Loop

Gripple Hook Tab (Motor)

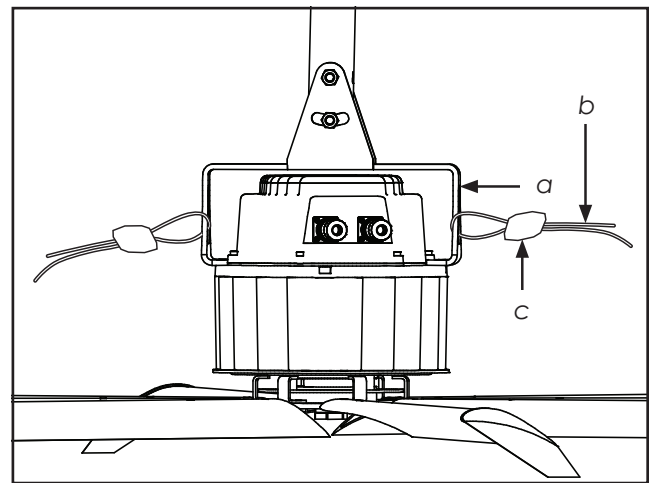

- a Gripple Hook Tab
- b Guy Wire
- c Gripple Fastener

Gripple Maximum Angle

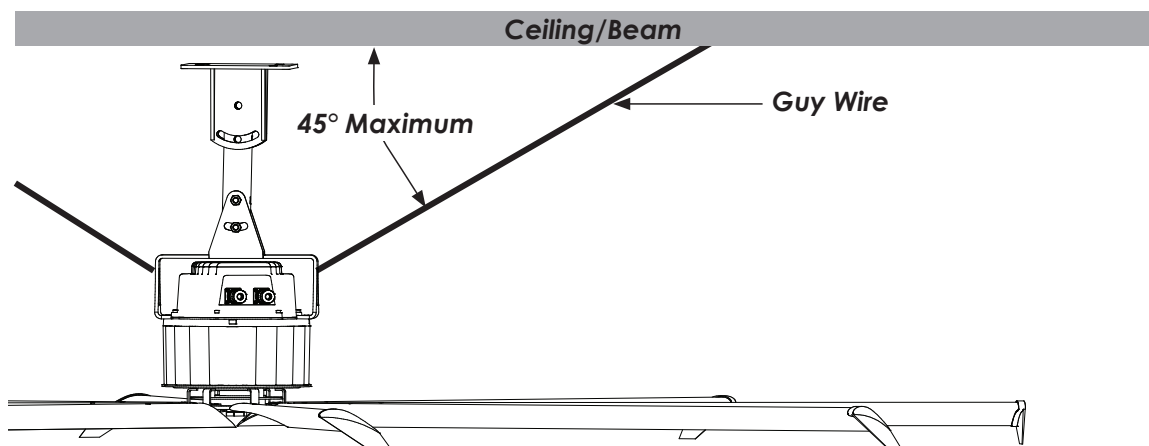

8 INSTALLING BLADES

⚠ WARNING/ AVERTISSEMENT

To reduce the risk of personal injury, do not bend the blade brackets when installing the brackets, balancing the blades, or cleaning the fan. Do not insert foreign objects in between rotating fan blades.

Pour réduire le risque de blessure, ne pas plier les crochets lame lors de l'installation des crochets, l'équilibre entre les lames, ou de nettoyer la ventilateur. Ne pas insérer d'objets étrangers entre les pales du ventilateur.

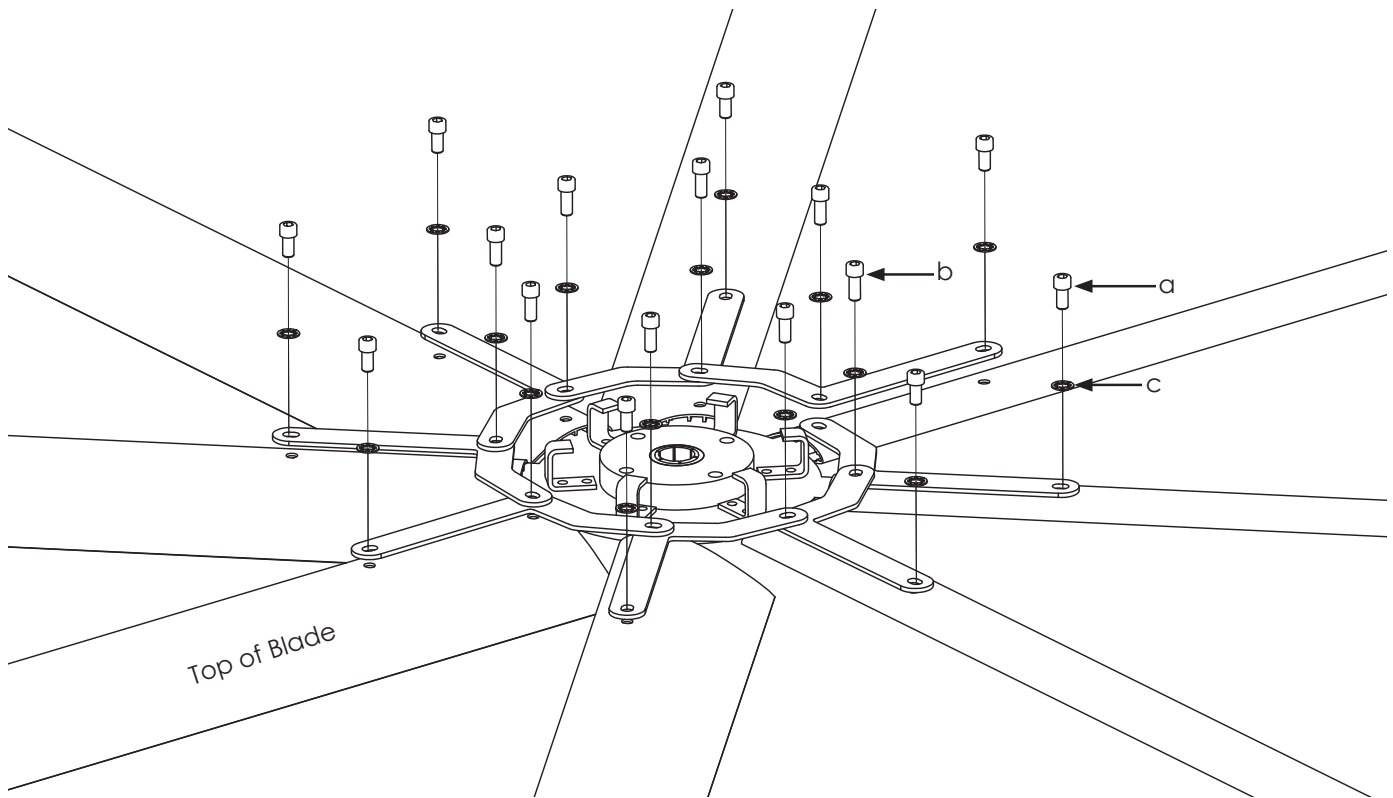

- a.** (Soc Cap 5/16-18 x 3/4) must be installed on the outer section of the blade.
 - b.** (Soc Cap 5/16-18 x 5/8) must be installed on the inner section of the blade.
- Each Soc Cap requires one (1) **c.** Zinc Split Lock Washer 5/16.

Blade Hardware Kit (supplied):

- a.** (8) Soc Cap 5/16-18 x 3/4
- b.** (8) Soc Cap 5/16-18 x 5/8
- c.** (16) Zinc Split Lock Washer 5/16

8 INSTALLING BLADES

8.1 Attach Blades to Hub:

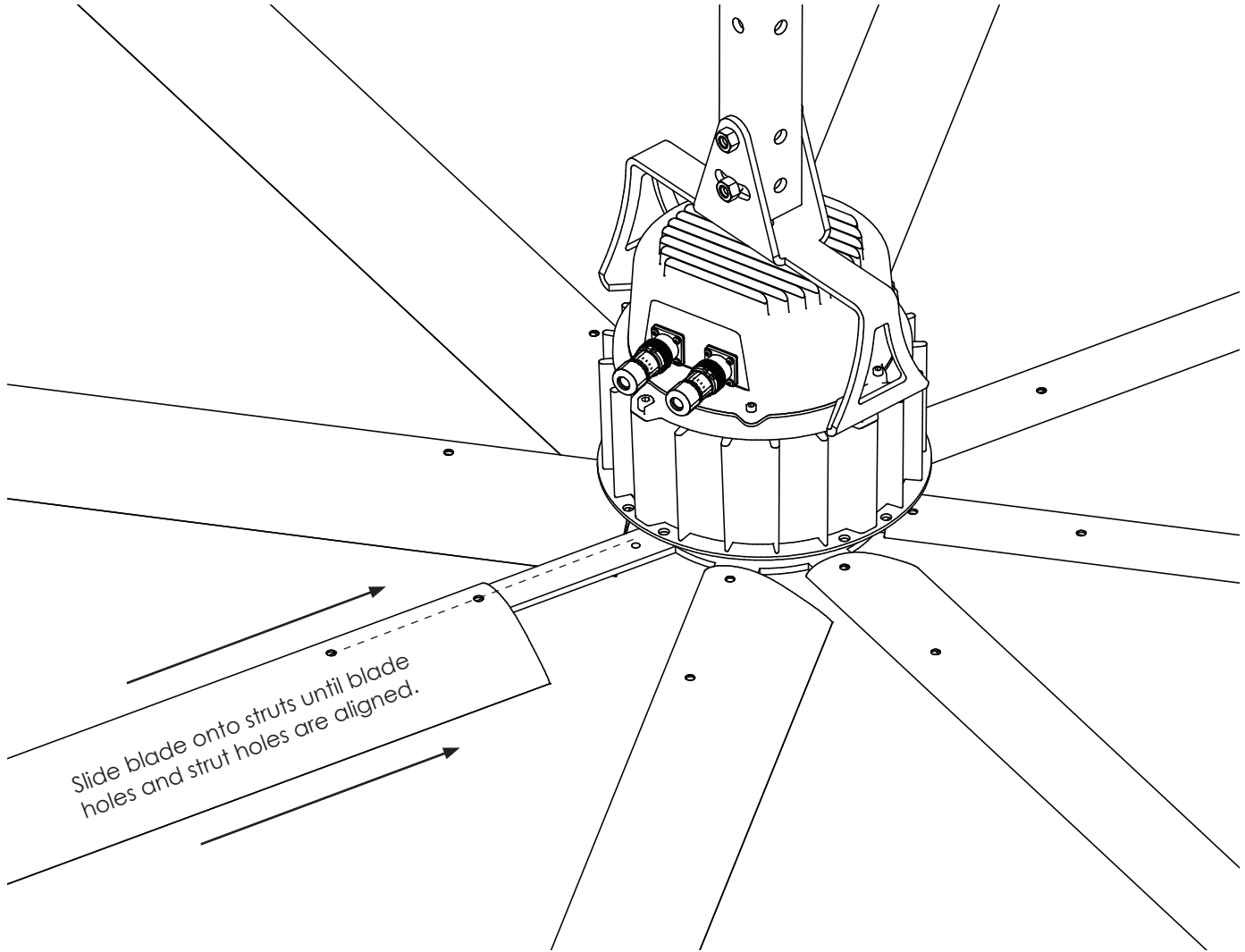

8 INSTALLING BLADES

8.2 Attach Boomerang Brackets:

WARNING/AVERTISSEMENT



Disconnect power to the motor before installing the blades.

Débranchez l'alimentation du moteur avant d'installer les lames.

Do not tighten the bolts until all the blade Boomerang Brackets are attached.

Ne serrez pas les boulons avant d'avoir fixé tous les supports de boomerang de lame.

Attach the Blade Boomerang Brackets using the Blade Hardware. Moving counter-clockwise, position the Boomerang Brackets as specified.

Hole A & B rests on the blade. Hole C will be positioned on top of the boomerang bracket of the blade previous. First, install all boomerang brackets and hardware by hand tightening. Second, tighten the blade bolts individually with a 1/4" allen wrench/hex key.

Blade Hardware Kit (supplied):

- a. (8) Soc Cap 5/16-18 x 5/8
- b. (8) Soc Cap 5/16-18 x 3/4
- c. (16) Zinc Split Lock Washer 5/16

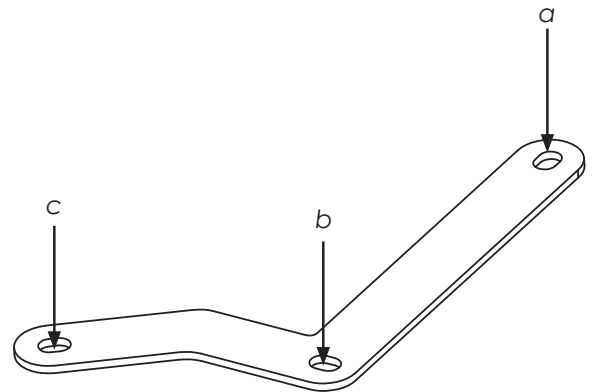

Blade Boomerang Brackets

ATTENTION: Upon completion of the mechanical installation of the fan and before powering on, spin the fan around multiple times by hand to ensure all brackets are clear from contact with other parts on the fan. Thoroughly inspect the hub, the bolts and brackets within the hub to guarantee clear and proper rotation. If you find that the fan has a bracket that is hitting another object on the hub, contact SkyBlade Fan Company for a resolution.

8 INSTALLING BLADES

8.3 Wingtip Assembly

Install wingtips on end of blade after blade has been securely attached to the strut. Fasten wingtip to blade using a 10-32 X 5/8 Button Cap.

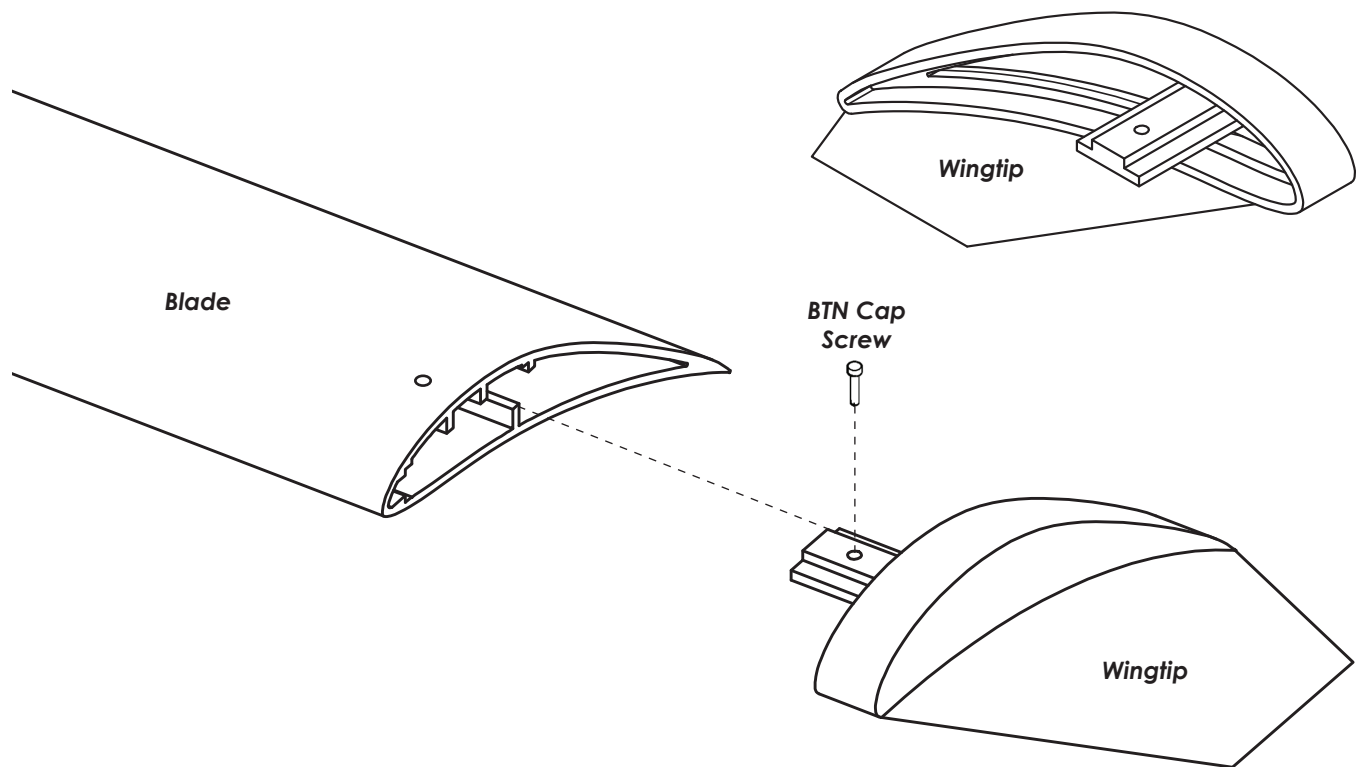

Wingtip Hardware Kit (supplied):

- a. (8) 10-32x3/8 BTN Cap Screw

9.1 Power Requirements:

INPUT VOLTAGE	INPUT (HZ)	INPUT/OUTPUT PHASE
110-115 VAC	50 / 60 Hz	1 Phase
200-240 VAC	50 / 60 Hz	1 Phase
220-240 VAC	50 / 60 Hz	3 Phase
400-480 VAC	50 / 60 Hz	3 Phase

⚠ WARNING/AVERTISSEMENT



Motor cables and incoming power must never be run in the same conduit. Failure to install per SkyBlade Fans instructions, including wiring, may be hazardous, cause premature failure, and void the manufacturers warranty.

Les câbles moteur et de la puissance entrant ne doivent jamais être placés sur le même conduit. Ne pas installer par Skyblade ventilateurs instructions, y compris le câblage, peut être dangereuse, entraîner une défaillance prématurée, et annulera la garantie du fabricant.

Notes/Remarques:

1. Fan should only be installed by qualified personnel in accordance with the NEC.
2. Proper grounding of fan per the NEC is required for safety and proper operation.
3. See controller brochure for specific controller max run lengths.
4. Each fan must be connected to individual circuit breaker.

Supply Connections: Conductor of a fan identified as grounded conductor to be connected to an ungrounded conductor of power supply, conductor of fan identified for equipment grounding to be connected to an equipment grounding conductor.

Do NOT remove the PCB from the driver housing. Doing so will damage the driver and is non warrantable.

⚠ CAUTION/ATTENTION

SkyBlade Fan Company is not liable for any voltage disturbances with explicit reference to electronic magnetic interference (EMI). Voltage disturbance refers to transient overvoltage, voltage unbalance, voltage swells, rapid voltage change, flicker, superimposed signals, harmonic voltages, supply voltage variations, voltage dips and frequency/time deviation.

SkyBlade Fan Company n'est pas responsable des perturbations de tension en référence explicite aux interférences magnétiques électroniques (EMI). Les perturbations de tension se réfèrent aux surtensions transitoires, aux déséquilibres de tension, aux hausses de tension, aux variations rapides de tension, au scintillement, aux signaux superposés, aux tensions harmoniques, aux variations de la tension d'alimentation, aux creux de tension et aux écarts fréquence / temps.

⚠ WARNING/AVERTISSEMENT**Electrical Shock Hazard.
RISQUE D'ÉLECTROCUTION.**

To reduce the risk of electrical shock, wiring should be performed by a qualified electrician. Incorrect assembly can cause electrical shock or damage the motor and the controller.

Pour réduire le risque d'électrocution, le câblage doit être effectué par un électricien qualifié. Assemblage incorrect peut provoquer des chocs électrique ou endommager le moteur et le contrôleur.

To reduce the risk of fire or electrical shock, do not use this fan with any solid-state speed control device.

Pour réduire le risque d'incendie ou de choc électrique, ne pas utiliser ce ventilateur avec un dispositif de contrôle de vitesse à l'état solide.

The installation of a SkyBlade Fan must be in accordance with the National Electrical Code, ANSI/NFPA 70-1999, and all local codes. The procedures and techniques outlined in this manual are merely a guide for proper installation. Code compliance is YOUR responsibility. Failure to comply with these codes could result in personal injury or property damage.

L'installation d'un ventilateur Skyblade doit être en conformité avec le National Electrical Code, ANSI / NFPA 70-1999, et tous les codes locaux. Les procédures et les techniques décrites dans ce manuel sont seulement un guide pour une installation correcte. Respect du Code est de VOTRE responsabilité. Le non respect de ces codes peut entraîner des blessures ou des dommages matériels.

The fan controllers contain high voltage capacitors which continue to hold a charge after removal of its main supply. Before working on the fan controller, ensure isolation of mains supply from line inputs at the fan controllers disconnect (L1, L2, L3). Wait three (3) minutes for capacitors to discharge to safe voltage levels. Darkened display LEDs are NOT an indication of safe voltage levels. Failure to do so may result in personal injury or death. **DO NOT DISASSEMBLE THE MOTOR OR ITS ONBOARD DRIVE!** Doing so greatly increases the risk of shock.

Les contrôleurs de ventilateur contiennent des condensateurs à haute tension qui continuent de maintenir une charge après l'enlèvement de l'alimentation principale. Avant de travailler sur le contrôleur du ventilateur, assurez-vous que l'alimentation électrique des entrées de ligne au niveau des disjoncteurs des ventilateurs se déconnecte (L1, L2, L3). Attendez trois (3) minutes pour que les condensateurs se déchargent à des niveaux de tension sécurisés. Les LED éclaircies ne sont PAS une indication de niveaux de tension sécurisés. Le fait de ne pas faire beaucoup entraîne des blessures corporelles ou la mort. **NE DÉMONTEZ PAS LE MOTEUR OU SON ENTRAÎNEMENT À BORD!** Cela augmente considérablement le risque de choc.

⚠ CAUTION/ATTENTION

An incorrectly installed controller can result in component damage or reduction in the fan's life. Wiring or application errors such as under-sizing the controller, incorrect or inadequate AC supply, or excessive ambient temperatures may result in a malfunction of the fan system. Verify correct voltage, phase, and horsepower before beginning installation.

Un contrôleur mal installé peut entraîner des dégâts matériels ou la réduction de la durée de vie du ventilateur. Câblage ou d'application des erreurs telles que le sous-dimensionnement du contrôleur, une alimentation ca incorrecte ou inadaptée ou des températures ambiantes excessives peuvent provoquer un dysfonctionnement du système de ventilation. Vérifiez que la tension correcte, la phase et puissance avant de commencer l'installation.

⚠ WARNING/AVERTISSEMENT



Exercise caution and common sense when powering the fan. Do not connect the fan to a damaged or hazardous power source. Do not attempt to resolve electrical malfunctions or failures on your own. Contact SkyBlade Fans at 1-586-806-5107 if you have any questions regarding electrical installation of this fan.

Faites preuve de prudence et de bon sens lorsque vous alimentez le ventilateur. Ne pas brancher le ventilateur à une source d'alimentation endommagé ou dangereux. Ne pas tenter de résoudre les dysfonctionnements électriques ou des échecs sur votre propre. Contactez Skyblade fans au 1-586-806-5107 si vous avez des questions concernant l'installation électrique de ce ventilateur.

⚠ CAUTION/ATTENTION

For use with manufacturer supplied motor and drive only.
Not for use with other speed control devices.

Pour utilisation avec le moteur fourni par le fabricant et le lecteur uniquement.
Ne pas utiliser avec d'autres appareils de contrôle de vitesse.

To avoid a short circuit, be very careful not to get metal chips in the control.

Pour éviter un court-circuit, faire très attention de ne pas obtenir des copeaux de métal dans le contrôle.

The SkyBlade Fan product warranty will not cover equipment damage or failure that is caused by improper installation.

La garantie des produits Skyblade Fan ne couvrira pas les dommages à l'équipement ou de l'échec qui est causé par une mauvaise installation.

IMPORTANT: Check that the correct input voltage is being sent to the fan. See rating labels on the motor for acceptable voltage. A blown fan due to incorrect input voltage is NOT covered under SkyBlade warranty.

9

ELECTRICAL INSTALLATION

9.2 Running the Motor Wire

The SkyBlade TurboProp series' custom designed chassis makes for running the motor wire in an incognito fashion. The motor wire slot on the top of the chassis allows the power wire to be ran through (or affixed to the side) of the extension bar, then conveniently through the top plate of the chassis and directly in to the motor electrical box. See diagram below.

9.3 Input Power Cable Wiring Schematics

IMPORTANT: Grounding of the incoming power on the motor is required.

NOTE: Skyblade Suggests using a field supplied fused disconnect switch.

1 Phase Voltage: 120V/1Ph, 230V/1Ph

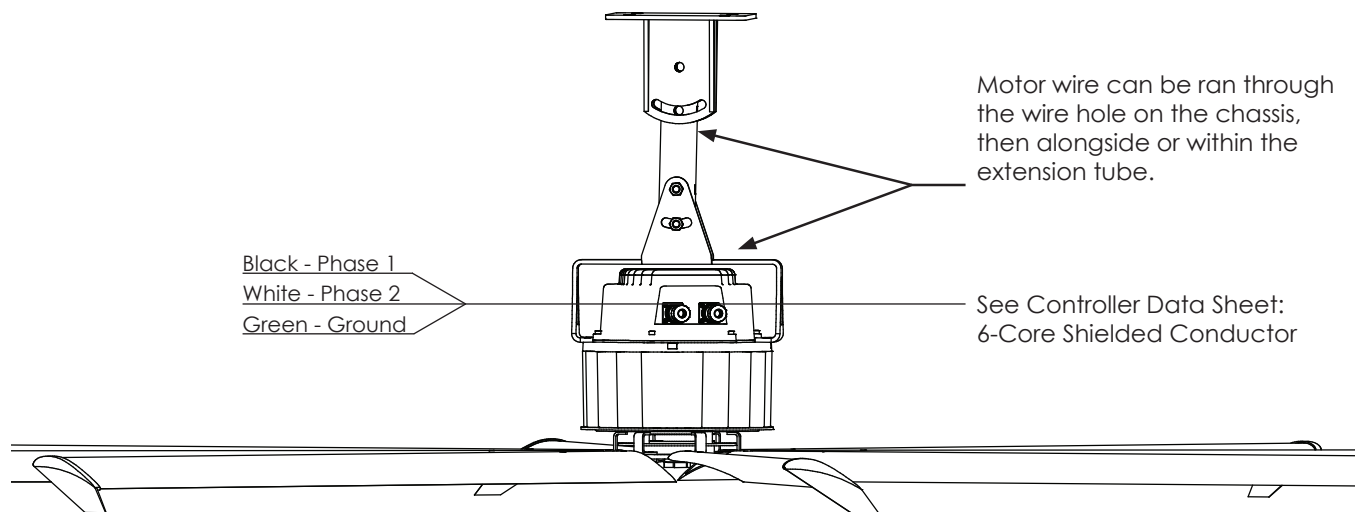

3 Phase Voltage: 230V/3Ph, 460V/3Ph

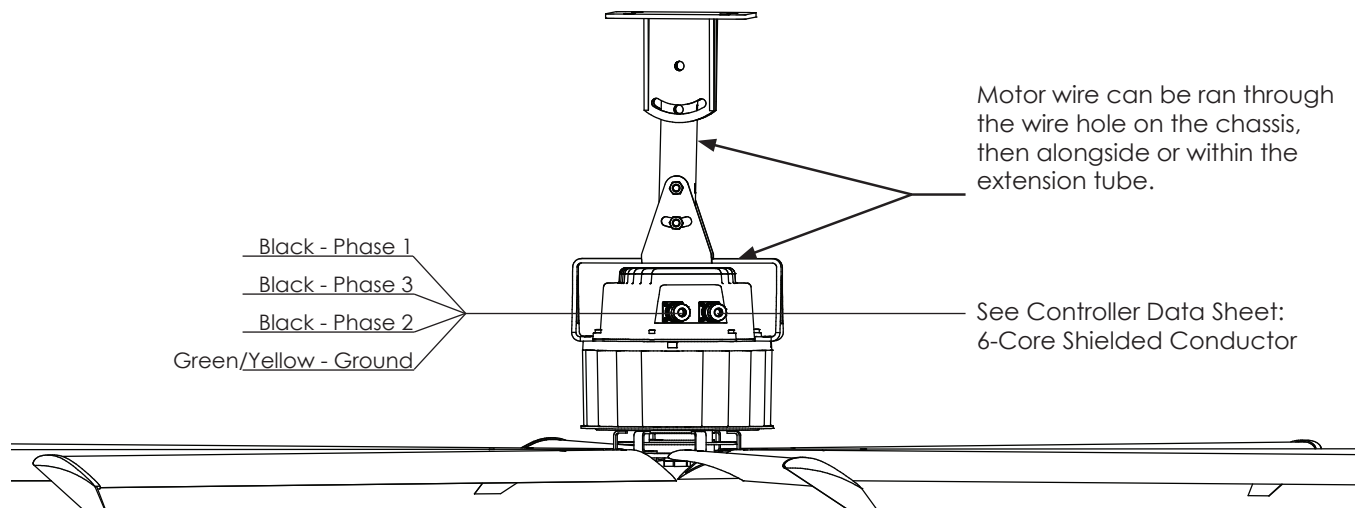

9.4 Wiring to a Fire Alarm Panel

If the installation of the fan is required to be wired to a fire alarm emergency shut-off, an external relay will have to be placed by a fire suppression specialist between the voltage line feed and the fan(s).

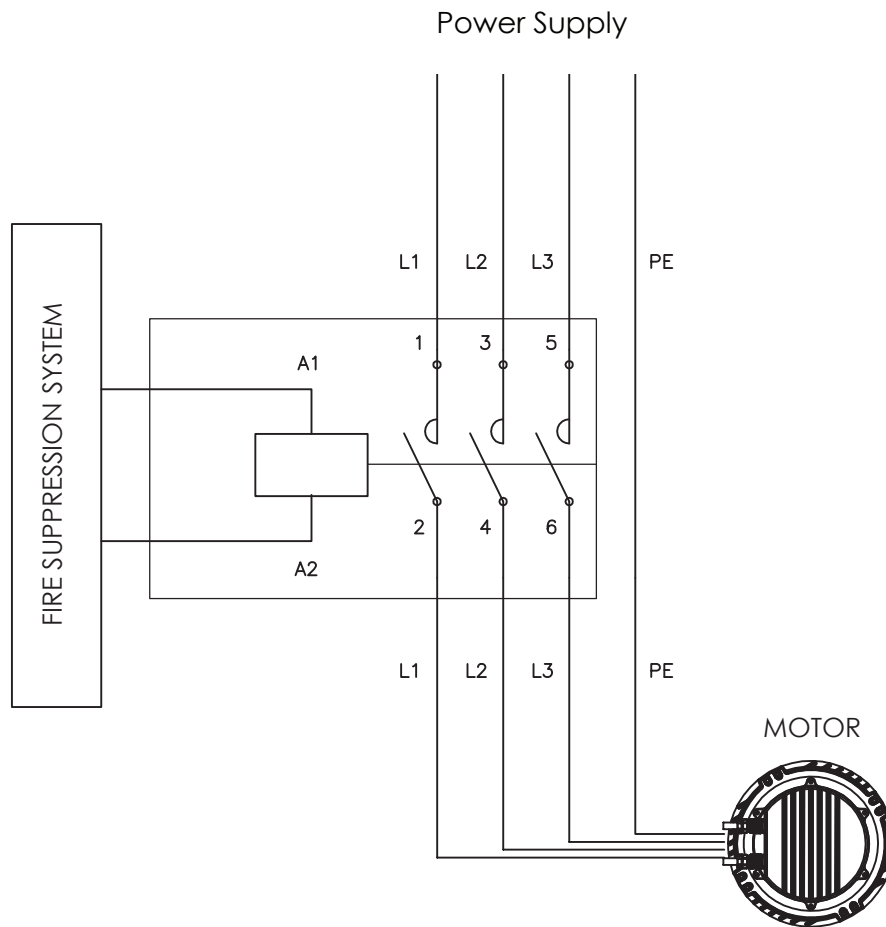

10 TROUBLESHOOTING

⚠ WARNING/AVERTISSEMENT



Electrical Shock Hazard. RISQUE D'ÉLECTROCUTION.

Risk of fire, electric shock, or injury to persons during cleaning and user-maintenance! Disconnect the appliance from the power supply and allow sufficient time for electrical discharge before servicing.

Risque d'incendie, de choc électrique ou de blessures lors du nettoyage et de l'entretien par l'utilisateur! Débranchez l'appareil de l'alimentation et de soins permettra suffisamment de temps pour la décharge électrique avant l'entretien.

Before servicing or cleaning unit, switch power off at the service panel and lock the service disconnecting means to prevent power from being switched on accidentally.

Avant de réparer ou de nettoyer l'appareil, coupez l'alimentation électrique au panneau de service et bloquez les dispositifs de sectionnement pour éviter une mise en marche accidentelle.

When service or replacement of a component in the fan requires the removal or disconnection of a safety device, the safety device is to be reinstalled or remounted as previously installed.

Lorsque le service ou le remplacement d'un composant dans le ventilateur nécessite le retrait ou la déconnexion d'un dispositif de sécurité, le dispositif de sécurité doit être réinstallé ou remonté comme précédemment installé.

1. Fan shakes while in use.

Shaking may be caused by a variety of problems, such as installing the fan in an open-sided structure causing a draft. In this case it may be necessary to secure additional restraints. Check the torque on all fasteners by using a calibrated torque wrench, DO NOT loosen and re-torque fasteners. If problem persists, please call the factory for assistance.

Although unlikely, mechanical resonance vibration is a possibility. In such case, contact factory for programming adjustments.

2. Fan will not start.

Ensure that the orange indicator LED is blinking. If the drive powers on but the fan still will not start, switch the VFD disconnect to "OFF" and check that the leads going to the motor are secured and connected properly. Double check the provided wiring diagram for controller wiring also. If the problem persists, have a qualified electrician troubleshoot the wiring.

3. Fan rotates in the wrong direction.

The fan should rotate in a counterclockwise direction when viewed from below. If this is not the case, ensure that both the controller and remote switch box are wired correctly.

4. The fan controller makes radio frequency (RF) noise.

The fan controller can generate RF noise in many ways, but this noise can be prevented by following the proper wiring practices outlined in the "Electrical Installation" section.

- a. Ensure proper grounding at the motor, controller, and from the controller to the supply.
- b. Do not run your controller and sensitive equipment on the same power line.
- c. Install properly sized EM/RFI filter.
- d. Contact Customer Service at **1-586-806-5107**.

5. LED indicator is not blinking in normal fashion.

Please contact Skyblade Fans customer service to resolve issue.

10 TROUBLESHOOTING

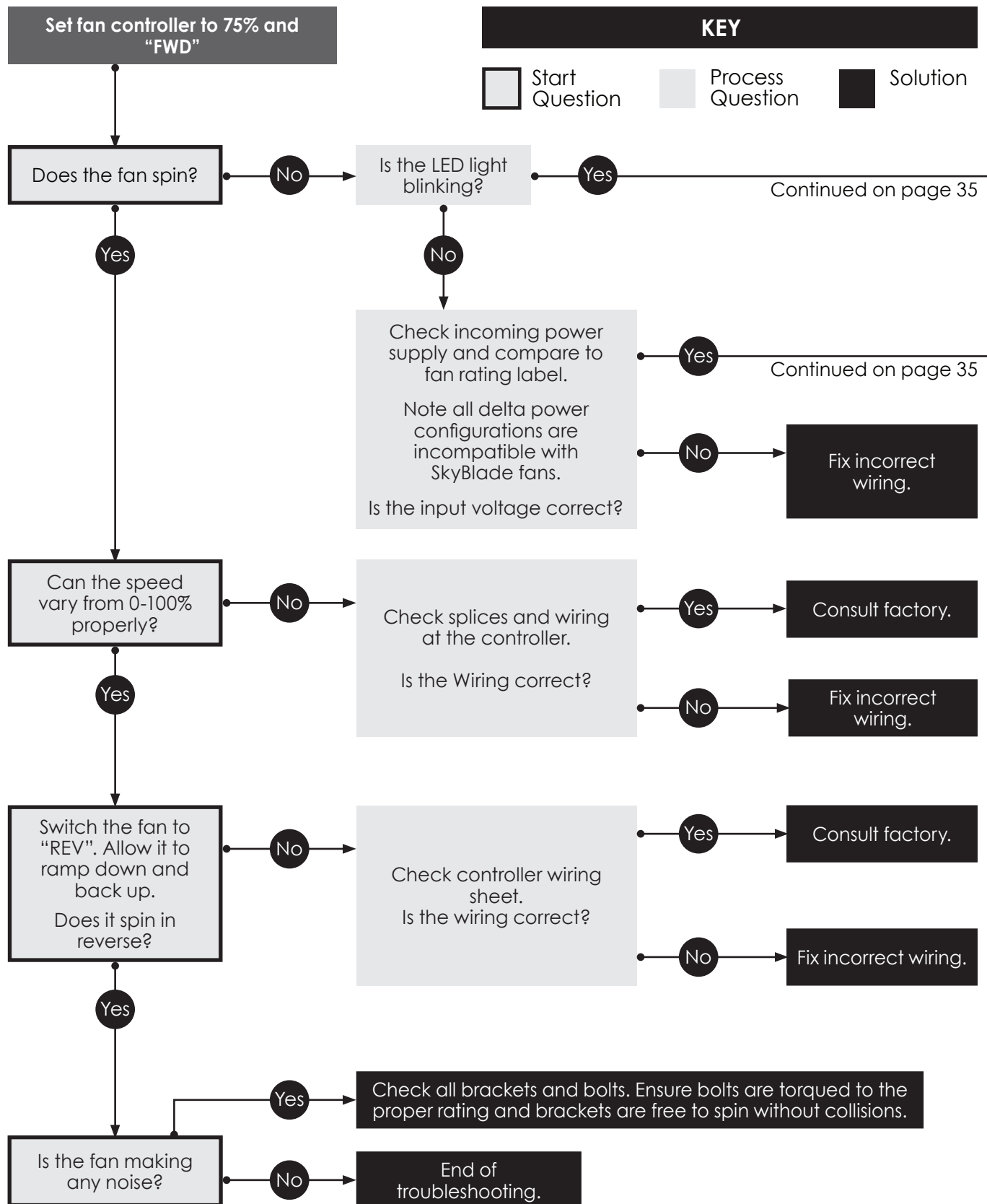

10 TROUBLESHOOTING

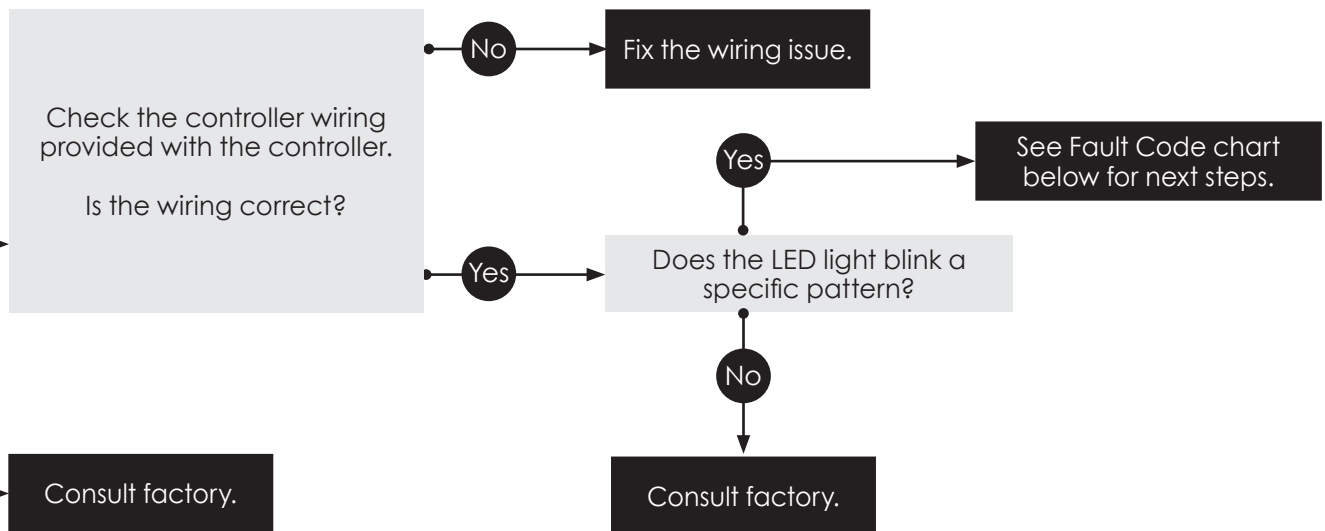

FAULT CODES	
1 Blink/3 Seconds	The fan is operating normally.
Voltage 5 Blinks/Second	<p>The Drive is undergoing some voltage issue. Make sure that the correct voltage is going to the fan.</p> <ul style="list-style-type: none"> • If the voltage is high at splice of the fan motor. Over-volt may be occurring a line reactor may need to be placed to reach correct voltage. • If the voltage is low at splice of the fan motor. Under-volt may be occurring a line reactor may need to be placed to reach correct voltage.
Vibration 8 Blinks/Second	Check all brackets and bolts. Ensure bolts are torqued to the proper rating.
Overtemp 7 Blinks/Second	If multiple fan diameters are being used make sure the correct blades are on the motor. Verify that no external disturbances are occurring with the blades.
No LED Light	<ul style="list-style-type: none"> • If incorrect voltage is wired to the fan it may cause the drive to Blown. Driver will need to be replaced . Contact Factory. • If the wrong fuse is placed on the breaker and a spike occurs the drive may have been blown. Driver will need to be replaced . Contact Factory

NOTE: Fan blades must be ON in order to troubleshoot.

11 PARTS

11.1 TurboProp HVLS Fan Parts Diagram

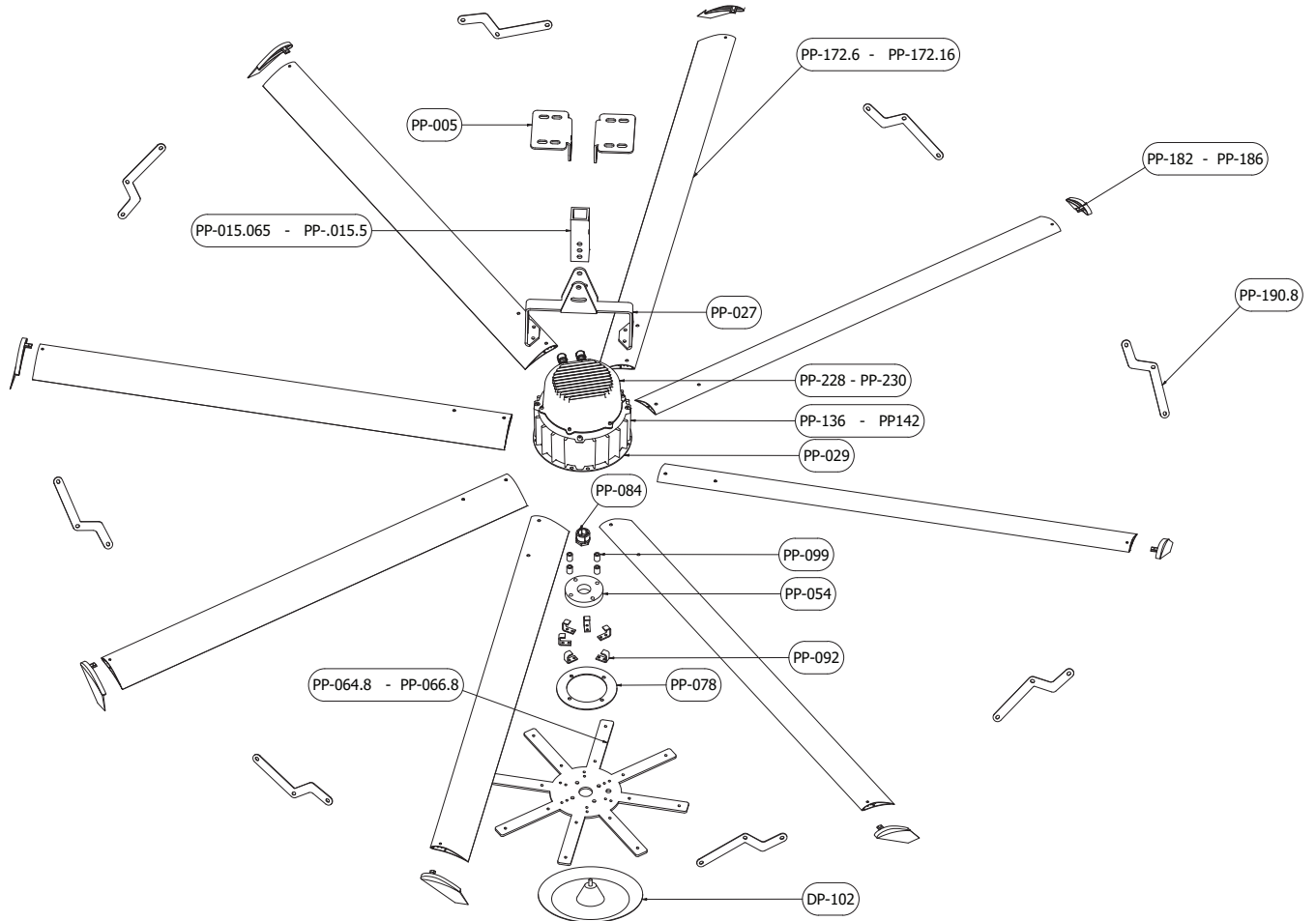

PART #	DESCRIPTION	PART #	DESCRIPTION
PP-005	Upper Yoke (Silver)	PP-136	1 Ph Motor - 6' to 10' models
PP-015.065	Extension Bar (6.5-in. - Aluminum)	PP-138	3 Ph Motor - 6' to 10' models
PP-015.1	Extension Bar (1-ft. - Aluminum)	PP-140	1 Ph Motor - 12' to 14' models
PP-015.2	Extension Bar (2-ft. - Aluminum)	PP-142	3 Ph Motor - 12' to 14' models
PP-015.3	Extension Bar (3-ft. - Aluminum)	PP-154	1 Ph Motor - 16' models
PP-015.4	Extension Bar (4-ft. - Aluminum)	PP-156	3 Ph Motor - 16' models
PP-015.5	Extension Bar (5-ft. - Aluminum)	PP-172.6	6' Mini Blades
PP-027	Chassis (Silver)	PP-172.8	8' Mini Blades
PP-029	Chassis Bottom Plate (Steel)	PP-172.10	10' Mini Blades
PP-054	Hub Cylinder (8 Silver Mini Blade) 6'-16' Fans	PP-172.12	12' Mini Blades
PP-064.8	Hub Plate (8 Silver Mini Blade) 8'-16' Fans	PP-172.14	14' Mini Blades
PP-066.8	Hub Plate (8 SS Mini Blade) 8'-16' Fans	PP-172.16	16' Mini Blades
PP-078	Safety Plate	PP-182	Red Wing Tip
PP-084	Trantorque Bushing	PP-184	Blue Wing Tip
PP-092	Small C Brackets	PP-186	Black Wing Tip
BP-094	Gripple Wire Packet	PP-190.8	8 Blade Boomerang Bracket
PP-099	Safety Plate Spacer	PP-228	Driver (1 Phase)
DP-102	Hub Plate Cover	PP-230	Driver (3 Phase)

⚠ WARNING/AVERTISSEMENT

Risk of fire, electric shock, or injury to persons during cleaning and user-maintenance!
Risque d'incendie, de choc électrique ou de blessures lors du nettoyage et de l'entretien par l'utilisateur!

Disconnect the appliance from the power supply and allow sufficient time for electrical discharge before servicing.

Débranchez l'appareil de l'alimentation électrique et laissez suffisamment de temps pour la décharge électrique avant l'entretien.

Before servicing or cleaning unit, switch power off at the service panel and lock the service disconnecting means to prevent power from being switched on accidentally.

Avant de réparer ou de nettoyer l'appareil, coupez l'alimentation électrique au panneau de service et bloquez les dispositifs de sectionnement pour éviter une mise en marche accidentelle.

When service or replacement of a component in the fan requires the removal or disconnection of a safety device, the safety device is to be reinstalled or remounted as previously installed. Failure to comply may result in serious personal injury.

Lorsque le service ou le remplacement d'un composant dans le ventilateur nécessite le retrait ou la déconnexion d'un dispositif de sécurité, le dispositif de sécurité doit être réinstallé ou remonté comme précédemment installé. Le non-respect peut entraîner des blessures graves.

Maintenance Checklist:

1. Ensure all mounting bolts are present and torqued to 90 ft-lb (122 N-m) using a calibrated torque wrench.
2. Ensure all bolts securing blades to the struts are present and torqued to 29 ft-lb (39 N-m) using a calibrated torque wrench.
3. Inspect power input terminations inside the connector plug and ensure their tightness.
4. Check all connections of the fan controller and ensure their tightness.
5. Ensure blades are secured to one another by boomerang brackets.
6. Ensure screws securing wingtips to blades are tight.
7. Check for the presence of the safety cable and gripple clips. The cable should be wrapped around the I-beam or angle irons, leaving as little slack as possible. The wire rope clips should be securely fastened on the top side of the I-beam or angle irons.
8. Administer proper cleaning techniques such as dusting blades, motor, reducer and chassis. If desired, used a water based cleaner to polish blades.

If you have any questions, please contact customer service at **1-586-806-5107**.



SkyBlade Fans | Where Form Follows Function

14 Aristoc Road, Glen Waverley VIC 3150

1300 556 380 | sales@hnr.com.au

www.SkyBladeFans.com.au

SkyBlade® and **SkyBlade Fans®**
are the trademarks of SkyBlade Fans.



LIMTBP.0123_19